

FISCAL COURT ORDERS

JULY 19, 2022

BOOK 43

REGULAR SESSION OF NELSON FISCAL COURT

PAGE 590

COURT MET IN REGULAR SESSION, PRESENT COUNTY JUDGE-EXECUTIVE DEAN WATTS AND THE FOLLOWING NAMED MAGISTRATES: KEITH METCALFE, GARY COULTER, BERNARD ICE, JEFF LEAR AND ERIC SHELBURNE.

RESOLUTION

On motion of Keith Metcalfe, second of Jeff Lear, by unanimous vote of the court, IT IS HEREBY ORDERED to approve the dedication of the Fiscal Court Meeting Room to honor Bernard Ice. It will now be called the Bernard E Ice Room. See page 595.

RESOLUTION

Judge Watts proclaims Friday July 22 2022 as Dennis Wells Days for his bravery and dedication responding and entering a house fire in a dangerous situation to possibly save a life. See page 596.

MINUTES APPROVED JULY 5, 2022 REGULAR MEETING

On motion of Keith Metcalfe, second of Eric Shelburne, by unanimous vote of the court, IT IS HEREBY ORDERED to approve the minutes of the July 5, 2022 Regular Fiscal Court meeting.

BILLS- TRANSFERS-ADDITIONAL BILLS

On motion of Eric Shelburne, second of Gary Coulter, by unanimous vote of the court, IT IS HEREBY ORDERED to authorize the County treasurer to pay the following bills, additional bills and to make the following transfers as presented. See pages 597-603.

FISCAL COURT ORDERS

JULY 19, 2022

BOOK 43

REGULAR SESSION OF NELSON FISCAL COURT

PAGE 591

BARDSTOWN BOURBON COMPANY INDUSTRIAL REVENUE BONDS

On motion of Bernard Ice, second of Eric Shelburne, by unanimous vote of the court, IT IS HEREBY ORDERED to approve a Resolution and Memorandum of Agreement. See Pages 604-613.

SHERIFF'S STATE AND LOCAL TAX SETTLEMENT (PENDING AUDIT)

On motion of Gary Coulter, second of Jeff Lear, by unanimous vote of the court, IT IS HEREBY ORDERED to approve the Sheriff's State and Local Tax Settlement (Pending Audit) as presented. See pages 614-627.

LOUISVILLE WATER MEMORANDUM

On motion of Jeff Lear, second of Eric Shelburne, by unanimous vote of the court, IT IS HEREBY ORDERED to approve the Louisville Water Memorandum as presented. See pages 628-635.

MEMORANDUM OF AGREEMENT AND CONTRACT

On motion of Keith Metcalfe, second of Gary Coulter, by unanimous vote of the court, IT IS HEREBY ORDERED to approve the Memorandum of Agreement and Contract as presented between City of New Haven and Nelson County Fiscal Court. See page 636.

FISCAL COURT ORDERS

JULY 19, 2022

BOOK 43

REGULAR SESSION OF NELSON FISCAL COURT

PAGE 592

SENATE BILL 135-OPEN NEW BANK ACCOUNT

On motion of Jeff Lear, second of Keith Metcalfe, by unanimous vote of the court, IT IS HEREBY ORDERED to approve opening a new bank account used only by the County Clerk to purchase supplies and equipment for Record Storage. See pages 637-648.

ANNEXATION AGREEMENT WITH THE CITY OF BARDSTOWN

On motion of Gary Coulter, second of Jeff Lear, by unanimous vote of the court, IT IS HEREBY ORDERED to approve the Annexation Agreement with the City of Bardstown. See pages 649-651.

ADVERTISE FOR NEW MAINTENANCE TRUCK

On motion of Bernard Ice, second of Eric Shelburne, by unanimous vote of the court, IT IS HEREBY ORDERED to approve advertising for purchasing a new maintenance truck.

ROAD DEPARTMENT REPORT

A- RESOLUTION

On motion of Bernard Ice, second of Eric Shelburne, by unanimous vote of the court, IT IS HEREBY ORDERED to approve the County Road List Resolution as presented. See pages 652-667.

B-VEHICLE REPAIR

On motion of Eric Shelburne, second of Jeff Lear, by unanimous vote of the court, IT IS HEREBY ORDERED to approve the purchase of a reman engine. See page 668.

On motion of Gary Coulter, second of Bernard Ice, by unanimous vote of the court, IT IS HEREBY ORDERED to approve the Resolution and Agreement between Fiscal Court and The Commonwealth of Kentucky as presented and authorize Judge Watts to sign all documents. See pages 668-685.

FISCAL COURT ORDERS

JULY 19, 2022

BOOK 43

REGULAR SESSION OF NELSON FISCAL COURT

PAGE 593

ROAD DEPARTMENT REPORT-CONTINUED

County Assistant Road Supervisor Lee Mattingly presented to the Court the County Road Department Report. See page 686.

County Assistant Road Supervisor Lee Mattingly advised the court of his upcoming retirement.

JAIL REPORT

Jailer John Snellen presented to the court the regular Jail report. See pages 687-688.

EMA/EMS

Director Joe Prewitt presented to the court the regular EMS report. See page 000.

LANDFILL/SOLID WASTE

County Landfill Manager/Engineer John Greenwell updated the court on the continuing projects at the Landfill.

RECREATION REPORT

Recreation Director Derrick Hagan updated the court on the Park reports.

FISCAL COURT ORDERS

JULY 19, 2022

BOOK 43

REGULAR SESSION OF NELSON FISCAL COURT

PAGE 594

OLD/NEW BUSINESS

Magistrate Coulter asked about an Ordinance pertaining to burnt houses in the County.

Magistrate Coulter asked the court to start looking into purchasing new Voting Machines.

Magistrate Metcalfe recognized the Judge Watts for all the years of service to Nelson County.

Sheriff Pineiroa presented a shadow box to Judge Watts for his service to Nelson County with memorandum from all County Departments.

On motion of Dean Watts, second of Bernard Ice, by unanimous vote of the court, IT IS HEREBY ORDERED to adjourn the July 19, 2022 regular session Fiscal Court.

DEAN WATTS, NELSON COUNTY JUDGE/EXECUTIVE

JEANETTE HALL SIDEBOTTOM, NELSON COUNTY CLERK

FISCAL COURT ORDERS

JULY 19, 2022

BOOK 43

REGULAR SESSION OF NELSON FISCAL COURT

PAGE 595



NELSON COUNTY - KENTUCKY

DEAN WATTS, County Judge Executive
P.O. BOX 578 • One Court Square, 2nd Floor
BARDSTOWN, KENTUCKY 40004-0578

Phone: (502) 348-1800
Fax: (502) 348-1873

Resolution Dedicating and Naming of the Nelson County Fiscal Court Room

WHEREAS, Bernard Elmer Ice served Nelson County as Magistrate for District 3 for 36 years; and

WHEREAS, Bernard Elmer Ice's positive contributions both to District 3 and the County as a whole are recognized;

NOW THEREFORE BE IT RESOLVED that Nelson County Fiscal Court hereby dedicates this meeting room in his honor and names the Fiscal Court Room the "Bernard E. Ice" Room.

BE IT FURTHER RESOLVED, Nelson County Fiscal Court directs that a plaque be placed naming of the "Bernard E. Ice" Room.



County Judge/Executive



Date



Working For Progress In Unity With

FISCAL COURT ORDERS

JULY 19, 2022

BOOK 43

REGULAR SESSION OF NELSON FISCAL COURT

PAGE 596



NELSON COUNTY - KENTUCKY

DEAN WATTS, County Judge Executive
P.O. BOX 578 • One Court Square, 2nd Floor
BARDSTOWN, KENTUCKY 40004-0578

Phone: (502) 348-1800
Fax: (502) 348-1873

PROCLAMATION DENNIS WELLS DAY

WHEREAS: Deputy Sheriff Dennis Wells responded to a house fire that was occupied by an elderly woman; and

WHEREAS: Smoke had filled the house and Deputy Wells was advised that the woman may still be inside of the smoke filled house; and

WHEREAS: Deputy Wells entered the house under very dangerous conditions to check for anyone that may still be inside; and

WHEREAS: Deputy Wells put his own life on the line and showed great courage; and

THEREFORE I, Dean Watts, Nelson County Judge Executive do hereby proclaim Friday, July 22, 2022 as Dennis Wells Day in Nelson County; and

ENCOURAGE: The people of Nelson County to recognize Dennis Wells for his bravery and dedication!

Signed this the 19th day of July, 2022.

A handwritten signature in black ink, appearing to read 'Dean Watts', is written over a horizontal line.

Dean Watts, Nelson County Judge Executive



Working For Progress In Unity With

... ..

FISCAL COURT ORDERS

JULY 19, 2022

BOOK 43

REGULAR SESSION OF NELSON FISCAL COURT

PAGE 597

**Nelson County Fiscal Court
Bills for Court Approval
July 19, 2022**

Name	Memo	Account	Amount
01 General Fund			
ADP	Payroll processing fees	9100301 - Payroll Processing	\$ 661.75
All State Truck Sales	Service truck	5090340 - Maintenance - Vehicle Maint	116.15
American Tire	SO 4, 16, 43	5105479 - Law Enforc Tires	2,021.16
American Tire	Tires - Logan	5115479 - Codes - Tires	786.61
American Tire	Tires - zero turn	5401427 - Recreation Maint Supplies	235.01
Aqua Treat	Cooling tower water treatment	5081329 - Justice Center Maint Contracts	150.00
Aqua Treat	Geothermal water treatment	5415329 - Civic Center Maint Contracts	184.80
Barrie, Jennifer	Sheriff office cleaning - 0622	5105329 - Law Enforc Bldg Maint Contracts	750.00
Bluegrass Integrated Comm	June 2022 postcards	5065427 - Elections Supplies	180.00
BMS LLC	Annual renewal fee- cafeteria plan	9400205 - Employee Health Insurance	150.00
Bumper to Bumper	Brake pads	5205340 - Animal Control Vehicle Expense	54.95
Bumper to Bumper	Filter	5401427 - Recreation Maint Supplies	13.95
Carey Sign	Decals	5105340 - Law Enforc Vehicle maintenance	575.00
Conway Heaton	Exhaust repairs - service truck	5090340 - Maintenance - Vehicle Maint	1,633.04
Danville Office	Folders, calculator paper	5001445 - CJE Office Expense	24.77
Danville Office	Paper	5040445 - Treasurer Office Supplies	59.99
Danville Office	Chair, envelopes, office supplies	5115445 - Codes - Office Expense	1,304.63
Duplicator Sales	Monthly copier agreement - shelter	5205445 - Animal Control Office supplies	28.72
Economy Pest Control	Pest control	5105329 - Law Enforc Bldg Maint Contracts	45.00
Economy Pest Control	Portable toilets- June 2022	5401364 - Recreation Rented Equipment	510.00
Estcam Clean	Carpet cleaning	5415329 - Civic Center Maint Contracts	200.00
Feed America Ky	June 2022 distribution	5330515 - Feed America Program	144.48
Friends of Wickland	Cleaning Jan-Jun 2022	5086329 - Wickland Maint Contracts	1,637.50
Galls	Misc officer uniforms	5105481 - Law Enforc Uniforms	1,726.89
Hillyard	Bleach, trash bags, towels, cleaning supply	5205411 - Animal Control Custodial Supply	502.62
Holt Computers	Service call	5115445 - Codes - Office Expense	278.00
Holt Computers	Computer - electrical inspector	5115725 - Codes Office Equipment	1,172.00
Hord Landscaping	Service sprinkler system	5080329 - Old Courthouse Maint Contracts	149.00
Humane Society	June 2022 clinic fees	5205549 - Animal Control Medical Expense	2,859.75
Intertech Mechanical	Replace unit CDW area	5081516 - A C, HVAC, Geothermal	-4,995.00
Johnson Controls	Annual fire alarm monitoring	5081329 - Justice Center Maint Contracts	815.72
KACo	Annual dues	9100551 - Memberships	1,100.00
KACo Fidelity Bonds	Treasurer bond	9100531 - Fidelity and Surety Bonds	305.40
KACo Insurance	2022-2023 Policy	5081521 - Justice Center Insurance	10,404.90
KACo Insurance	2022-2023 Commercial policy	9100521 - County insurance	258,561.27
KACO LGIA	Earthquake coverage 2022-2023	9100521 - County insurance	23,602.00
Kentucky One	Random, new employee testing	9400547 - Employee Medical	691.00
Leo Talbott & Sons	AC charge	5010516 - Sutherland Bldg Heat/Air Repair	1,285.00
Lowe's	Portable fencing	5090406 - County-wide Supplies, Materials	351.40
Lowe's	Supplies	5135427 - EMA Supplies & Materials	87.03
Midwest Vet Supply	Medical supply	5205549 - Animal Control Medical Expense	289.75
Monitronics	Quarterly alarm monitoring	5010329 - Sutherland Bldg Main Contracts	115.23
Monitronics	Quarterly alarm monitoring	5205329 - Animal Control Maint Contracts	110.70
MVP Garden Center	Mulch	5010329 - Sutherland Bldg Main Contracts	295.00
MVP Garden Center	Mulch, prune	5080408 - Old Courthouse Landscaping	1,519.99
MVP Garden Center	Mulch, prune	5415408 - Civic Center Landscaping	5,779.99
Nelson County Coroner	Transports - June 2022	5020308 - Coroner Autopsy & Services	1,700.00
Newcomb Oil Co	Fuel	5105429 - Law Enforc Fuel	10,639.11

FISCAL COURT ORDERS

JULY 19, 2022

BOOK 43

REGULAR SESSION OF NELSON FISCAL COURT

PAGE 598

**Nelson County Fiscal Court
Bills for Court Approval
July 19, 2022**

Name	Memo	Account	Amount
01 General Fund (continued)			
Newcomb Oil Co	Fuel	5135429 · FMA Fuel and Lubricants	552.25
Patrons Home Center	Ballasts	5010334 · Sutherland Bldg Maint	24.99
Patrons Home Center	Trash bags, towels, tissue	5010411 · Sutherland Bldg Custodial Suppl	194.47
Patrons Home Center	Banner snaps	5080334 · Old Courthouse Bldg Maint	4.99
Patrons Home Center	Towels, tissue	5080411 · Old Courthouse Custodial Supply	136.48
Patrons Home Center	Door kickstop	5081334 · Justice Center Building Maint	8.49
Patrons Home Center	Handrail repairs, ramp	5086334 · Wickland Building Maint	107.68
Patrons Home Center	Flush valves - stock	5090406 · County-wide Supplies, Materials	319.90
Patrons Home Center	Gorilla tape, wrench	5090427 · Maintenance - Supplies	29.28
Patrons Home Center	Keys	5101334 · Building Maintenance	2.69
Patrons Home Center	Washer repairs	5101336 · Equipment Repairs	23.46
Patrons Home Center	Bulbs	5105334 · Law Enforc Building Maint	143.70
Patrons Home Center	Air filters	5205334 · Animal Control Building Maint	16.49
Patrons Home Center	Door kickstop	5305334 · Sr Citizens Bldg Supplies	8.49
Patrons Home Center	Toilet repairs	5401334 · Recreation Bldg/Grounds Maint	12.49
Patrons Home Center	Bathroom supplies	5401411 · Recreation Bathroom Supplies	156.31
Patrons Home Center	Outdoor cleaner, keys, maintenance supplies	5401427 · Recreation Maint Supplies	174.89
Paxton Media Group	Delinquent tax listing	9100539 · Advertising & Legal Notices	3,560.25
Pet Health Services	Micro chips	5205427 · Animal Control Feed & supplies	440.00
Petty Cash	Licenses, tags	5001445 · CJE Office Expense	144.00
Quill Corporation	Toner	5001445 · CJE Office Expense	102.99
Quill Corporation	Toner	5040445 · Treasurer Office Supplies	96.99
Sheriff	Summons, transports, fiscal court 0422-0622	5015199 · Sheriff Fees Payable	1,255.21
SpecialPets Healthcare	Emergency medical service - injured dog	5205549 · Animal Control Medical Expense	210.59
Springfield Laundry	Mats, towels, soap, tissue	5010411 · Sutherland Bldg Custodial Suppl	432.14
Springfield Laundry	Mats	5080411 · Old Courthouse Custodial Supply	52.99
Springfield Laundry	Mats	5081411 · Justice Center Custodial Supply	655.34
Springfield Laundry	Mats	5105411 · Law Enforc Custodial Supplies	234.82
Springfield Laundry	Mats	5415411 · Civic Center Custodial Supplies	45.74
USPS	Annual PO Box fee	5001445 · CJE Office Expense	242.00
Vencill Enterprises	Repeater repairs - Cox's Creek	5105339 · Law Enforc Radios/Tower Comm	764.50
Willett's Lawn	Mowing Spraying June 2022	5081329 · Justice Center Maint Contracts	510.00
Willett's Lawn	Plaza, Greenspace mowing June 2022	5085315 · Contracted Services	300.00
Willett's Lawn	Football/Baseball mowing June 2022	5401329 · Recreation Maint Contracts	1,600.00
Willett's Lawn	Soccer mowing June 2022	5401329 · Recreation Maint Contracts	2,915.00
Willett's Lawn	Culvertown Park June 2022	5401329 · Recreation Maint Contracts	400.00
Willett's Lawn	Balltown Park June 2022	5401329 · Recreation Maint Contracts	280.00
Willett's Lawn	Fuel surcharge 0622	5401334 · Recreation Bldg Grounds Maint	300.25
Total 01 General Fund			357,264.12
02 Road Fund			
Airgas Mid America	Welding supplies	6105427 · Garage supplies	59.59
All State Truck Sales	Mechanic's truck	6105443 · Parts	118.56
American Tire	Backhoe	6105479 · Tires	416.15
Bardtown Mills	Pembrooke Dr	6105457 · Bridge & Culvert Materials	123.70
Bumper to Bumper	Shop supplies	6105427 · Garage supplies	94.62
Bumper to Bumper	Gradall Trucks 307, 308, Mechanic, Backhoe	6105443 · Parts	591.42
Bumper to Bumper	Socket tool	6105475 · Tools	9.89
Cintas	Uniforms	6105481 · Uniforms	835.16

FISCAL COURT ORDERS

JULY 19, 2022

BOOK 43

REGULAR SESSION OF NELSON FISCAL COURT

PAGE 599

**Nelson County Fiscal Court
Bills for Court Approval
July 19, 2022**

Name	Memo	Account	Amount
02 Road Fund (continued)			
CMI Equipment	Boom mower	6105443 - Parts	256.40
East Penn	Battery - sign truck	6105443 - Parts	149.27
Fastenal	420E Backhoe	6105443 - Parts	17.91
Galeton	Vests, gloves	6105594 - Crew Safety Equipment	273.95
Haydon Materials	Quarry Loop, Hall Simpson, Mobley Mill	6105457 - Bridge & Culvert Materials	746.73
Irving Materials Inc.	Hall Simpson	6105457 - Bridge & Culvert Materials	1,785.00
Joe Hill's	Blades	6105427 - Garage supplies	29.99
Kentucky One	Random, new employee testing	9400547 - Employee Medical	100.00
Keystops	Fuel and antifreeze	6105429 - Fuel and Lubricants	20,086.74
Lasco	Filters	6105443 - Parts	50.44
Patrons Home Center	Sprayers, torch blade, lights	6105427 - Garage supplies	83.17
Patrons Home Center	Propane	6105429 - Fuel and Lubricants	106.76
Patrons Home Center	Fence repair - Hutchins Ridge	6105537 - Property damage claims	11.98
Patrons Home Center	Water cooler	6105594 - Crew Safety Equipment	57.99
Quill Corporation	Safety glasses	6105594 - Crew Safety Equipment	218.70
T&T Feed & Seed	Weed killer	6105431 - Fences, ROW, Tree Removal	119.00
Tatum Auto Supply	Plated lever action	6105427 - Garage supplies	19.99
Tatum Auto Supply	Trucks 301, 306, boom mower, gradall, tractor	6105443 - Parts	438.36
Total Truck Parts	Tie down chain	6105427 - Garage supplies	116.85
Truck Parts & Service	Steel, shop supplies	6105427 - Garage supplies	112.32
Truck Parts & Service	Truck 309, Ram 5500, tractor	6105443 - Parts	960.73
Vinitow, Brian Isaac	Boot allowance	6105481 - Uniforms	100.00
Yaste, Terry	Boot allowance	6105481 - Uniforms	100.00
Total 02 Road Fund			28,191.37
03 Jail Fund			
CDA Inc.	Electronic Monitors 0622 GPS	5101314 - Contracts with Other Counties	536.25
Clems	Food	5101425 - Food	3,428.35
Combined Public Comm	Telephone cards	5101428 - Canteen Inventory	1,634.00
Craftmaster Hardware	Onsite estimate - jail locks	5101741 - Jail Building	1,000.00
Diamond Drugs Inc	Pharmacy 0622	5101549 - Routine Medical	970.67
Flowers Baking Co	Bread	5101425 - Food	666.97
Gordon Foods	Dishwasher lease	5101336 - Equipment Repairs	76.00
Gordon Foods	Cleaning and custodial supply	5101411 - Custodial Supplies	1,971.28
Gordon Foods	Kitchen supplies	5101423 - Food Prep & Serving Supplies	379.36
Gordon Foods	Food	5101425 - Food	9,041.83
Gordon Foods	Canteen inventory	5101428 - Canteen Inventory	277.75
Hunt Family Dentistry	Inmate medical	5101549 - Routine Medical	367.00
ISET, LLC	Telephone service call	5101329 - Building Maint Contracts	615.00
Kenny's Laundry	Laundry services 6-29-22	5101330 - Laundry Services	633.75
Kentucky One	Random, new employee testing	9400547 - Employee Medical	130.00
Kerr Office Plus	Monthly copier charge	5101428 - Canteen Inventory	48.83
Kerr Office Plus	Monthly copier charge	5101445 - Office Supplies	135.59
Landmark Sprinkler	Annual inspection	5101329 - Building Maint Contracts	215.00
Leo Talbot & Sons	AC service call	5101516 - Heating and Air Conditioning	635.00
Maxima Supply	Inventory	5101428 - Canteen Inventory	1,800.40
O'Dell Equipment, Inc.	Service call/repairs - washing machine	5101336 - Equipment Repairs	610.87
Patrons Home Center	Plunger, gorilla glue, trimmer line	5101406 - Tools and maint supplies	39.85
Patrons Home Center	Drain opener	5101411 - Custodial Supplies	23.99

FISCAL COURT ORDERS

JULY 19, 2022

BOOK 43

REGULAR SESSION OF NELSON FISCAL COURT

PAGE 600

**Nelson County Fiscal Court
Bills for Court Approval
July 19, 2022**

Name	Memo	Account	Amount
03 Jail Fund (continued)			
Prairie Farms	Milk	5101425 - Food	973.30
Tyler Mountain Water	Water	5101445 - Office Supplies	58.70
Vendengine Inc	Commissions for canteen transactions	5101428 - Canteen Inventory	667.35
Your Choice Uniforms	Staff Uniforms	5101481 - Staff Uniforms	8,043.00
Total 03 Jail Fund			34,980.09
04 LGFA Fund			
Haydon Materials	Humphrey Ln	6105409 - Rock	925.53
Mago Construction	Independence Ave, Tom Greer, Harrison Fork	6105405 - Hot and cold mix	15,770.01
Total 04 LGFA Fund			16,695.54
09 Ambulance Fund			
3-D Graphics	Embroidery fees	5140481 - Staff Uniforms	384.00
American Tire	Sq 33, 35, 36, 37	5140340 - Vehicle Maintenance & Repairs	1,843.50
American Tire	Sq 33, 35, 36, 37	5140443 - Vehicle Parts	4,431.13
Bound Tree Medical	Medical supply	5140550 - Medical supplies & Materials	614.15
Conway Heaton	Sq 31	5140340 - Vehicle Maintenance & Repairs	60.00
Conway Heaton	Sq 31	5140443 - Vehicle Parts	609.88
Danville Office	Printer ink, paper	5140445 - Office Expense	653.84
EMSAR	Quarterly contract billing	5140336 - Equipment Maintenance & Repairs	1,508.75
Galls	Uniforms	5140481 - Staff Uniforms	119.95
Kentucky One	Random, new employee testing	9400547 - Employee Medical	100.00
Louisville Metro EMS	ACLS, CPR cards	5140569 - Training	24.00
Lowe's	Floor rug	5140446 - Housing expenses	196.64
Newcom Oil Co	Fuel	5140429 - Fuel	14,844.07
NexAir	Oxygen	5140550 - Medical supplies & Materials	115.72
QuadMed Inc	Medical supply	5140550 - Medical supplies & Materials	585.30
Quick Care Express	Sq 39	5140340 - Vehicle Maintenance & Repairs	595.00
Quick Care Express	Sq 36, 37	5140439 - Oil, lubes	252.36
Quick Care Express	Sq 39	5140443 - Vehicle Parts	1,165.07
Sam's Club	Kitchen supplies	5140411 - Custodial supplies	169.11
Tatum Auto Supply	Antifreeze	5140439 - Oil, lubes	83.94
TriZetto Provider Solutions	Electronic claims	5140445 - Office Expense	231.04
Total 09 Ambulance Fund			28,587.45
13 Solid Waste Fund			
American Tire	Shop tires	5215479 - Tires	7,094.68
Auxier, Tim	Boot allowance	5215481 - Employee uniforms	74.98
City of Bardstown	Quarterly Agreed Order City/County Garbage	5215566 - Reimbursements	1,938.00
Kentucky One	Random, new employee testing	9400547 - Employee Medical	65.00
Keystops	Fuel	5215429 - Fuel & Lubricants	22,213.85
Lasco	Trucks 414, 419, 420, 423	5215443 - Parts	2,941.95
Opal's Dream Foundation	Nat Rogers, Hwy31E New Haven	5215315 - Roadside Cleanup	400.00
Patrons Home Center	Dumpster repair	5215443 - Parts	7.04
Salt River	Garbage billing services	5215320 - Collection Contracts	12,182.80
Salt River	1257 delinquent accts rebilled quarterly	5215320 - Collection Contracts	691.35
Springfield Laundry	Uniforms	5215481 - Employee uniforms	603.53
Tatum Auto Supply	Trucks 416, 420, 422, 423	5215443 - Parts	219.03
Total 13 Solid Waste Fund			48,432.21

FISCAL COURT ORDERS

JULY 19, 2022

BOOK 43

REGULAR SESSION OF NELSON FISCAL COURT

PAGE 601

**Nelson County Fiscal Court
Bills for Court Approval
July 19, 2022**

Name	Memo	Account	Amount
15 Landfill Fund			
Advanced Analytical Solutions	Testing supplies	5210581 - Leachate Maintenance	48.24
American Tire	Truck 725	5210479 - Tires	765.73
Boyd Co	Compactor, Highlift	5210443 - Parts	4,434.28
Duplicator Sales	Monthly copier agreement	5210445 - Office Expense	24.67
GBA	Delivery and service tickets	5210445 - Office Expense	1,155.00
Hall, Derek	CDL permit testing	5210445 - Office Expense	86.58
Haydon Materials	Rock	5210571 - Property Maintenance	807.50
Haydon Materials	Force main access road	8011750 - Landfill Phase Construction	5,455.00
Kentucky One	Random, new employee testing	9400547 - Employee Medical	200.00
Keystops	Fuel and lubricants	5210429 - Fuel & Lubricants	23,814.33
Ky Environment/Div Waste M	Quarterly fee	5210314 - Environmental Remediation Fee	35,518.00
Lasco	Truck 417	5210443 - Parts	11,601.89
Lewis, Ronnie	Boot allowance	5210481 - Uniforms	100.00
Long, Michael T	DOT physical	5210445 - Office Expense	75.00
Masters Supply Inc	Pipe fittings	5210443 - Parts	26.22
Modern Supply	Welding supply - rental fee	5210427 - Main supplies	24.00
Patrons Home Center	Hitch ball	5210443 - Parts	69.99
Quill Corporation	Toner, sharpies	5210445 - Office Expense	90.98
Springfield Laundry	Cleaning supplies	5210427 - Main supplies	180.90
Springfield Laundry	Uniforms	5210481 - Uniforms	472.48
Tatum Auto Supply	Starter fluid	5210427 - Main supplies	75.48
Tatum Auto Supply	Trucks 417, 421, highlift, engineer	5210443 - Parts	655.08
Truck Parts & Service	Wheel studs, tire repairs, roll off supplies	5210443 - Parts	511.40
Total 15 Landfill Fund			86,192.75
23 Occupational Tax Fund			
Danville Office	Envelopes, pens	5047445 - OLF Office supplies	580.47
Total 23 Occupational Tax Fund			580.47
84 ARPA Grant			
Horizon Engineering	Water line designs - various ARPA projects	8099 743 10 - Misc ARPA Water Projects	5,946.00
Total 84 ARPA Grant			5,946.00
Bills for Approval			\$606,870.00

FISCAL COURT ORDERS

JULY 19, 2022

BOOK 43

REGULAR SESSION OF NELSON FISCAL COURT

PAGE 602

**Nelson County Fiscal Court
Additional Bills for Court Approval
July 19, 2022**

Name	Memo	Account	Amount
01 General Fund			
ADP	Payroll processing 063022	9100301 · Payroll Processing	\$ 57.40
BMS LLC	0722	9400299 · Cobra Administration	72.15
Duncan Septic Service	Grease trap maintenance	5305329 · Sr Citizen Bldg Maint Contracts	300.00
KACo Workers Comp	Workers comp insurance FY 2023	9400209 · Workers Comp Insurance	58,775.30
Nelson Co Implement	Lawn mower repair	5340427 · Comm Svc Supplies	189.75
Total 01 General Fund			<u>59,394.60</u>
02 Road Fund			
KACo Workers Comp	Workers comp insurance FY 2023	9400209 · Workers Comp Insurance	46,521.52
Martin, Chris	Boot allowance	6105481 · Uniforms	100.00
Prime Choice Bldg Supply	Woodlawn Bridge	6105312 · Bridges	9.58
Total 02 Road Fund			<u>46,631.10</u>
03 Jail Fund			
Duncan Septic Service	Grease trap maintenance	5101329 · Building Maint Contracts	300.00
Hunt Family Dentistry	Inmate medical	5101549 · Routine Medical	670.25
KACo Workers Comp	Workers comp insurance FY 2023	9400209 · Workers Comp Insurance	27,290.19
Southern Health Partners	Health services contract	5101549 · Routine Medical	10,668.23
Southern Health Partners	Medical expenses - inmates	5101549 · Routine Medical	774.78
Total 03 Jail Fund			<u>39,703.45</u>
09 Ambulance Fund			
KACo Workers Comp	Workers comp insurance FY 2023	9400209 · Workers Comp Insurance	96,301.41
Total 09 Ambulance Fund			<u>96,301.41</u>
13 Solid Waste Fund			
KACo Workers Comp	Workers comp insurance FY 2023	9400209 · Workers Comp Insurance	46,820.24
Total 13 Solid Waste Fund			<u>46,820.24</u>
15 Landfill Fund			
KACo Workers Comp	Workers comp insurance FY 2023	9400209 · Workers Comp Insurance	49,125.96
Total 15 Landfill Fund			<u>49,125.96</u>
23 Occupational Tax Fund			
KACo Workers Comp	Workers comp insurance FY 2023	9400209 · Workers Comp Insurance	64.57
Total 23 Occupational Tax Fund			<u>64.57</u>
Total Additional Bills			<u>\$ 338,041.33</u>

FISCAL COURT ORDERS

JULY 19, 2022

BOOK 43

REGULAR SESSION OF NELSON FISCAL COURT

PAGE 603

NELSON COUNTY FISCAL COURT FY 2023 Paid Bills/Upcoming Transfers for Court Approval July 19, 2022			
Fund/Vendor	Description	Account	Amount
<u>General Fund</u>			
AIA Kentucky	Training - electrical inspector	5115569 - Code Enf Training and Education	\$ 95.00
Kimball Midwest	Air freshener	5081411 - Justice Center Custodial Supply	98.16
	Less Discount		(0.98)
Tractor Supply	Litter	5205427 - Animal Control Feed & supplies	\$3.96
<u>Road Fund</u>			
Lawson Products	Garage supplies	6105427 - Garage supplies	104.45
	Less Discount		(1.06)
<u>Landfill Fund</u>			
Citation Equipment	Garage supplies	5210427 - Main supplies	315.95
TOTAL PAID BILLS AND TRANSFERS			\$ 665.48

FISCAL COURT ORDERS

JULY 19, 2022

BOOK 43

REGULAR SESSION OF NELSON FISCAL COURT

PAGE 604

RESOLUTION NO. 1 - 2022

A RESOLUTION OF THE NELSON COUNTY GOVERNMENT, GIVING PRELIMINARY APPROVAL OF AN INDUSTRIAL REVENUE BOND FINANCING FOR THE BARDSTOWN BOURBON COMPANY, LLC, AND ANY AFFILIATES OR ASSIGNEES THEREOF; AUTHORIZING INITIATION OF THE ACQUISITION, CONSTRUCTION, EQUIPPING, AND INSTALLATION OF AN INDUSTRIAL PROJECT; AGREEING TO UNDERTAKE THE ISSUANCE OF ONE OR MORE SERIES OF INDUSTRIAL REVENUE BONDS AT THE APPROPRIATE TIME OR TIMES; AUTHORIZING THE EXECUTION AND DELIVERY OF A MEMORANDUM OF AGREEMENT IN CONNECTION WITH THE ISSUANCE OF THE BONDS; AND TAKING OTHER PRELIMINARY ACTIONS.

WHEREAS, the Fiscal Court of the Nelson County Government (the "Issuer"), has determined that the Issuer may assist The Bardstown Bourbon Company, LLC, a Kentucky limited liability company, its affiliates and assigns (collectively, the "Company"), by pursuing the acquisition, construction, equipping, and installation of its distillery expansion, an industrial project of the Company consisting of the facilities and properties described in EXHIBIT A attached hereto (collectively, the "Project"), and by entering into, at the appropriate time, a lease agreement with the Company (the "Lease Agreement") pertaining to the Project, all pursuant to the authority of Sections 103.200 to 103.285, inclusive, of the Kentucky Revised Statutes ("KRS"), as amended (the "Act"), and in furtherance of the purposes of the Act and the ensuing public benefit to the residents of the Issuer and its environs, the Lease Agreement to be upon terms and conditions as the Act may require and as the Issuer may deem acceptable; and

WHEREAS, the Company has represented to the Issuer that the acquisition, construction, equipping, and installation of the Project, if acquired, constructed, equipped, and installed, will result in new job opportunities within the environs of the Issuer; and

WHEREAS, the Issuer is authorized by the Act to issue its industrial revenue bonds for the purpose of defraying the costs of acquiring, constructing, equipping, and installing "industrial building" facilities, which term means all real and personal properties suitable for the Project, including land, buildings, fixtures and equipment; discussions have occurred between representatives of the Company and the Issuer regarding the issuance of industrial revenue bonds by the Issuer to finance the Company's Project; it is the intention of the Issuer, and the Issuer has agreed and hereby agrees with the Company, to issue such industrial revenue bonds upon compliance by the Company with such reasonable conditions and obligations as the Issuer may require and documents incident to such bond issue or issues and upon the agreement of the Company to pay the reasonable costs and expenses of the Issuer related to or arising from such issuance from bond proceeds or other sources; and the Issuer has authorized the Company to proceed with the initiation of the acquisition, construction, equipping, and installation of the Project, subject to reimbursement of the costs of such acquisition, construction, equipping, and installation from the proceeds of the industrial revenue bonds, as and when issued; and

WHEREAS, based upon the Company's present estimate of the aggregate costs of the Project together with a reasonable allowance for contingencies and incidental costs, the Issuer proposes to issue its industrial revenue bonds in an aggregate stated principal amount up to

FISCAL COURT ORDERS

JULY 19, 2022

BOOK 43

REGULAR SESSION OF NELSON FISCAL COURT

PAGE 605

\$110,786,102.00, for a term of thirty years, to pay the costs of the acquisition of the Project (the "*Bonds*"), including costs incident to the authorization, sale, and issuance of the Bonds and other financing costs, with the understanding that such amount may be increased by subsequent official action of the Issuer upon the Company's request; and the Bonds will be payable solely from payments to be made by the Company under the Lease Agreement and will not be payable from any funds or assets of the Issuer whatsoever; and

WHEREAS, the Issuer proposes to enter into the Lease Agreement with the Company at the appropriate time under which the Company will covenant and agree to pay amounts sufficient to provide for the payment of principal of and premium, if any, and interest on the Bonds together with all trustee, paying agent, and servicing agent's fees in connection with the Bonds and any other related charges as the same come due and payable; and

WHEREAS, to evidence the Issuer and the Company's preliminary agreement regarding these matters the parties propose to enter into a Memorandum of Agreement substantially in the form set out in **EXHIBIT B** attached hereto (the "*Memorandum of Agreement*");

NOW, THEREFORE, BE IT RESOLVED AND ORDERED BY THE FISCAL COURT OF THE NELSON COUNTY GOVERNMENT, AS FOLLOWS:

Section 1. It is hereby found, determined, and declared that the recitals set forth above are hereby incorporated in this Section 1 by reference.

Section 2. It is found, determined, and declared that (a) the recitals set forth in the preambles to this Resolution, which are incorporated in this Section 1 by reference, are true and correct; (b) the amount of money necessary to be provided by the Issuer through the issuance of the Bonds for the acquisition, construction, installation, and equipping of the Project will be an aggregate amount up to \$110,786,102.00, the Bonds to have a term of thirty years; (c) the Company has represented it intends to have sufficient financial resources to acquire, construct, install, and equip the Project and to place it in operation and to continue to operate, maintain, and insure the Project throughout the term of the Bonds, meeting when due the obligations of the Lease Agreement; and (d) sufficient safeguards shall be provided by the Lease Agreement to insure that all money provided by the Issuer from the proceeds of the sale of the Bonds will be expended, by way of direct expenditure or reimbursement, solely and only for the purposes of the Project financed thereby.

Section 3. It is hereby found, determined, and declared that (a) the costs of acquiring, constructing, installing, and equipping the Project will be paid out of the proceeds of the Bonds, such proceeds to be supplemented by contributions of the Company as may be necessary to complete the Company's respective Project; (b) none of the Bonds will be general obligations of the Issuer; (c) neither the Bonds nor the interest thereon shall constitute or give rise to any pecuniary liability whatsoever of the Issuer or any charge against its general credit or taxing power; (d) the Bonds and the payment of interest thereon shall be secured and payable solely by a pledge of amounts to be paid by the Company or otherwise to be available under the Lease Agreement; (e) no part of said costs will be payable out of any general funds, assets, properties, or other contributions of the Issuer; (f)

FISCAL COURT ORDERS

JULY 19, 2022

BOOK 43

REGULAR SESSION OF NELSON FISCAL COURT

PAGE 606

the Issuer shall sell the Bonds only to the Company or an affiliated entity or assignee thereof; and (g) the Company shall pay the fees of the Issuer related to the Issuance of the Bonds .

Section 4. The acquisition, construction, installation, and equipping of the Project may be initiated and undertaken or caused to be initiated and undertaken by the Company forthwith, and the Company is authorized to formulate and develop plans and specifications for the Project and to enter into such contracts and undertakings as may be required for the acquisition, construction, installation, and equipping of the Project. Payments or reimbursements to or on behalf of the Company after the receipt of the proceeds of the sale of the Bonds by the Issuer shall be made as set out in the Lease Agreement.

Section 5. The Project constitutes an "industrial building" as provided in KRS 103.200(1)(k) and (n).

Section 6. The Company has requested, and the Issuer hereby approves, the employment of McBrayer PLLC as "Bond Counsel." Bond Counsel is authorized and directed to take any other legal action necessary or appropriate in connection with the issuance of the Bonds.

Section 7. The Company is authorized and directed to take any other legal action necessary and customary in order to satisfy any prerequisites to the issuance of the Bonds. Counsel for the Issuer and its officers and officials are authorized and requested to assist the Company in any appropriate manner.

Section 8. The Memorandum of Agreement attached hereto as EXHIBIT B is hereby approved, and the County Judge/Executive is hereby authorized to execute the Memorandum of Agreement on the Issuer's behalf. With notice to and approval from the Issuer, the Company may assign its rights hereunder by assigning the Memorandum of Agreement.

Section 9. No funds of the Issuer shall be expended for the costs of issuance of the Bonds or for the costs of the Project, except such as are derived from Bond proceeds.

Section 10. All resolutions, municipal orders, and other official actions of the Issuer or parts thereof in conflict herewith are, to the extent of such conflict, hereby rescinded.

Section 11. This Resolution shall be in full force and effect from and after its adoption.

[Signature Page to Follow]

FISCAL COURT ORDERS

JULY 19, 2022

BOOK 43

REGULAR SESSION OF NELSON FISCAL COURT

PAGE 607

[SIGNATURE PAGE TO INDUCEMENT RESOLUTION]

ADOPTED by the Fiscal Court of the County of Nelson, Kentucky, at a meeting held on July 19, 2022.

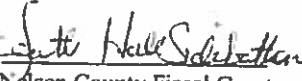

Dean Watts, County Judge/Executive

Attest: 

Clerk, Nelson County Fiscal Court

CERTIFICATION

I, the undersigned, do hereby certify that I am the duly qualified and acting Clerk of the Council of the Nelson County Government (the "Issuer"), and as such I further certify that the foregoing (with the attached EXHIBITS A and B), is a true, correct, and complete copy of a Resolution duly adopted by the Fiscal Court of the Issuer at a meeting properly held on July 19, 2022, signed by the County Judge/Executive and now in full force and effect, all as appears from the official records of the Issuer in my possession and under my control.

IN WITNESS WHEREOF, I have hereunder set my hand as of _____, 2022.

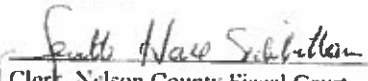

Clerk, Nelson County Fiscal Court

FISCAL COURT ORDERS

JULY 19, 2022

BOOK 43

REGULAR SESSION OF NELSON FISCAL COURT

PAGE 608

EXHIBIT A TO INDUCEMENT RESOLUTION

Project Description

The Project is an expansion of The Bardstown Bourbon Company, LLC and includes all industrial building facilities to be financed by the Bonds and to be acquired, constructed, installed, and equipped by the Company in and near the Nelson County Industrial Park consisting of land, real property improvements, and personal property at Nelson County PVA Parcel #63000-00-025, to add over 15,000 square feet to the Company's existing distillery, including fourteen warehouses, an addition to one of the Company's existing fermenter buildings, 16 new fermenters, a new distillation column and necessary equipment to accompany it, a hot water processing tank, grain handling equipment, chemical treatments, and glass towers to hold the still which will be visible from Bluegrass Parkway.

FISCAL COURT ORDERS

JULY 19, 2022

BOOK 43

REGULAR SESSION OF NELSON FISCAL COURT

PAGE 609

EXHIBIT B TO INDUCEMENT RESOLUTION MEMORANDUM OF AGREEMENT

This **MEMORANDUM OF AGREEMENT** (this "*Agreement*") is made as of July 19, 2022, by and between (a) the **NELSON COUNTY GOVERNMENT**, a Kentucky county government established pursuant to the provisions of Chapter 67A of the Kentucky Revised Statutes ("*KRS*" and the "*Issuer*"), and (b) **THE BARDSTOWN BOURBON COMPANY, LLC**, a Kentucky limited liability company, its affiliates and assigns (collectively, the "*Company*").

RECITALS

- A. The Issuer is authorized under KRS 103.200 to 103.285, inclusive (the "*Act*"), to issue industrial revenue bonds to finance the costs of acquiring, constructing, installing, and equipping certain industrial projects and facilities within the meaning of the Act, in order to accomplish the public purposes of promoting economic development within the Issuer's environs;
- B. The Company has advised the Issuer that the Company desires to finance the acquisition, construction, installation, and equipping of an industrial project within the meaning of the Act, consisting of the facilities and properties described in **EXHIBIT A** attached hereto (the "*Project*");
- C. The Company has asked the Issuer to issue industrial revenue bonds pursuant to the Act in an aggregate principal amount not to exceed \$110,786,102.00 for the purpose of financing the Project (the "*Bonds*");
- D. The parties hereto have found and determined that the financing of the Project will tend to accomplish the public purposes of the Act by causing economic development within the Issuer's environs;
- E. The Issuer proposes to issue the Bonds to finance the Project and desires to authorize the Company to proceed with the financing of the Project and be reimbursed from the proceeds of the Bonds for costs incurred related thereto before the issuance of the Bonds;
- F. The Issuer proposes to enter into, at the appropriate time and in accordance with the Act, a lease agreement with the Company (the "*Lease Agreement*"), pertaining to the Project, the Lease Agreement to be upon terms and conditions as the Act may require and the Issuer may deem acceptable;
- G. In order to obtain for the Issuer's residents the benefits listed above which the Project would create and preserve, the Issuer desires to encourage and induce the Company to proceed with the financing of the Project;
-

FISCAL COURT ORDERS

JULY 19, 2022

BOOK 43

REGULAR SESSION OF NELSON FISCAL COURT

PAGE 610

NOW, THEREFORE, in consideration of the premises and of the covenants and undertakings herein expressed, the Issuer and the Company hereby agree as follows:

Section 1. It is hereby found, determined, and declared that the recitals set forth in the preambles to this Agreement are hereby incorporated in this Section 1 by reference.

Section 2. The Company may commence the acquisition, construction, installation, and equipping of the Project and may provide or cause to be provided, at its own expense, any necessary interim financing to permit such acquisition, construction, installation, and equipping to commence and continue.

Section 3. Subject to the conditions provided herein, the Issuer will issue and sell the Bonds pursuant to the terms of the Act in an aggregate principal amount not to exceed \$110,786,102.00. The Bonds shall be signed by the manual or facsimile signature of the Issuer's County Judge/Executive and attested to by the Issuer's Clerk, shall bear interest at such rate or rates, shall be in such denomination or denominations, shall be subject to such terms of redemption, shall be in registered form, shall be payable as to principal, redemption price, and interest at such place or places, and shall contain such other terms and conditions as may be fixed by or pursuant to the Issuer's ordinance authorizing the sale and delivery thereof. The proceeds from the sale of the Bonds shall be used to finance the Project pursuant to the Act.

Section 4. The Issuer will cooperate with the Company for the purpose of issuing and selling the Bonds on the best terms reasonably obtainable; and if arrangements therefor satisfactory to the Issuer and the Company can be made, the Issuer will authorize the execution and delivery of such instruments and the taking of such further actions as may be necessary or advisable for the authorization, issuance, and sale of the Bonds on a negotiated basis and the use of the proceeds thereof to finance the Project, all as shall be authorized by law and mutually satisfactory to the Issuer and the Company. The Issuer shall sell the Bonds only to the Company or any affiliated entity or assignee thereof.

Section 5. Upon the issuance of the Bonds, the Issuer shall take title to the Company's Project and the Issuer and the Company shall enter into the Lease Agreement pursuant to which the Company will covenant and agree to pay amounts sufficient to provide for the payment of principal of and interest for the Bonds, together with all trustee, paying agent, and serving agent's fees in connection with the Bonds, and any other related charges as the same come due and payable. Issuer shall not be responsible for any costs related to or arising from the lease, including, but not limited to, building costs, repairs, and utilities.

Section 6. The Issuer shall take or cause to be taken such other acts and adopt or cause to be adopted such further proceedings as may be required to implement the aforesaid undertakings or as it may deem appropriate pursuant thereto. Upon request of the Company, the Issuer shall provide the written statement of assurance required by KRS 103.2101(6) that Issuer is in agreement with the negotiated financial arrangement for the issuance of the Bonds.

Section 7. Contemporaneously with the sale of the Bonds, the Company (a) will enter into the Lease Agreement with the Issuer, the terms of which shall obligate the Company to pay

FISCAL COURT ORDERS

JULY 19, 2022

BOOK 43

REGULAR SESSION OF NELSON FISCAL COURT

PAGE 611

the Issuer the amounts described in Section 5 hereof, as and when the same shall become due and payable, all provisions required by law and such other provisions as shall be mutually acceptable to the Issuer and the Company, and (b) will take such further acts and adopt such further proceedings as may be required to implement its aforesaid undertakings or as it may deem appropriate in pursuance thereof.

Section 8. The Company shall pay any established fees required by the Issuer related to the issuance of the Bonds.

Section 9. It is understood and agreed by and between the Issuer and the Company that the provisions hereof are not intended to, and shall not be construed or interpreted to, either (a) obligate or authorize the expenditure of any funds of the Issuer derived from any source whatsoever other than the proceeds from the issuance and sale of the Bonds as provided for herein; or (b) create any personal liability of the Issuer's present or future officers, officials, members, and employees, serving from time to time.

Section 10. No recourse shall be had for the payment of the principal of or premium or interest on any of the Bonds or for any claim based thereon or upon any obligation, covenant, or agreement therein contained against any past, present, or future officer, member, employee, or agent of the Issuer or the Commonwealth of Kentucky or any agency or political subdivision thereof, as such, either directly or through the Issuer or the Commonwealth of Kentucky or any agency or political subdivision thereof, under any rule of law or equity, statute, or constitution, or by the enforcement of any assessment or penalty or otherwise, and all such liability of any such officer, member, employee, or agent as such shall be expressly waived and released as a condition of and consideration for the execution and delivery of this Agreement and the issuance of the Bonds.

Section 11. With notice to and approval from the Issuer, the Company may assign its rights under this Agreement and shall provide notice of such assignment to the County Judge/Executive of the Issuer.

Section 12. If the parties are unable to agree to the terms of a Lease Agreement acceptable to the Issuer, the Issuer shall not be obligated to issue the Bonds.

Section 13. If the Company abandons the Project prior to the issuance of the Bonds, it shall notify the Issuer, whereupon this Agreement shall terminate. Upon any termination of this Agreement under this paragraph, neither the Issuer nor the Company shall have any further rights or obligations hereunder, except that the obligations of the Company under Sections 10 and 15 hereof shall survive any such termination.

Section 14. In the event that any tax relating to alcohol is abolished or modified by the state legislature during the term of the bonds, the Company agrees to annually pay to the Issuer and the School District a PILOT in the amount by which the County and School District's receipts are reduced by such action, provided that the total of the tangible personal property tax actually paid on the spirits in any one year, together with the PILOT paid in such year, shall not exceed the

FISCAL COURT ORDERS

JULY 19, 2022

BOOK 43

REGULAR SESSION OF NELSON FISCAL COURT

PAGE 612

amount that the Company would have paid in Spirits Tax at the rate and under the provisions of the law that apply on the date hereof.

Section 15. In the event of an Uncured Abandonment (as herein defined), a PILOT shall be due thereafter in an amount equal to the ad valorem taxes that would apply to the Project if this IRB did not exist, payable during the remaining Term of the IRB or until the IRB is otherwise terminated. An "Uncured Abandonment" shall be deemed to exist if at any time after the spirits warehouses included in the Project have been constructed, (i) the Company fails to store at least one-half of the quantity of spirits in each warehouse (such quantity to be set according to the Company's plans), and (ii) the Company fails to remedy such condition within six months thereof.

Section 16. If the Company substantially departs from the Project's plans as provided in its application and final development plan, the Issuer shall not be obligated to issue the Bonds.

Section 17. In order to induce the Issuer to execute and deliver this Agreement, the Company agrees to defend, indemnify, and hold the Issuer, its officials, members, employees, or agents harmless against any and all loss, cost, expense, claims, or actions arising out of or connected with the execution of this Agreement and the consummation of the transactions provided for herein and contemplated hereunder.

Section 18. This Agreement may be signed by each party upon a separate copy or separate signature page, and any combination of separate copies signed by all parties or including signature pages so signed will constitute a single counterpart of this Agreement. This Agreement may be signed in any number of counterparts, each of which will be deemed to be an original, but all of which together will constitute one and the same agreement. It will not be necessary, in proving this Agreement in any proceeding, to produce or account for more than one counterpart of this Agreement. This Agreement will become effective when one or more counterparts have been signed by each party, and delivered to the other parties, respectively. Any party may deliver an executed copy of this Agreement (and an executed copy of any documents contemplated by this Agreement) by facsimile transmission to another party or e-mailed .pdf files of scanned copies bearing their respective signatures, and such delivery will have the same force and effect as any other delivery of a manually signed copy of this Agreement (or such other document).

[Signature Page to Follow]

FISCAL COURT ORDERS

JULY 19, 2022

BOOK 43

REGULAR SESSION OF NELSON FISCAL COURT

PAGE 613

DocuSign Envelope ID: 093F3573-872B-48F7-B50C-92D9A805E39D

[SIGNATURE PAGE TO MEMORANDUM OF AGREEMENT]

NELSON COUNTY GOVERNMENT

Attest: Scott Hoff-Salt-Letterman
Clerk, Nelson County Fiscal Court

By: Dean Watts
Dean Watts, County Judge Executive

THE BARDSTOWN BOURBON COMPANY, LLC

DocuSigned by:
Mark W. W. Erwin
By: C35A311D1A0B4CC

FISCAL COURT ORDERS

JULY 19, 2022

BOOK 43

REGULAR SESSION OF NELSON FISCAL COURT

PAGE 614

2021-22 STATE TAX SETTLEMENT Ramon Pineiroa, NELSON COUNTY SHERIFF

CHARGES

	Assessment	Rate	Collection Amt.
Real Estate	3,436,419,552	0.00119	4,089,339.27
Leasehold	79,457,878	0.00015	11,918.85
Tangible/Rec Mach	130,291,875	0.0045	588,312.54
Inv/Fin Gd; Pub Wh; Vehic; Mfg Gp	181,010,282	0.0005	90,505.14
Manf Mach	419,242,723	0.0015	628,864.08
Boats & Atr; Unmfg Ag	11,378,000	0.00016	1,708.70
Tangible	1,059,177	0.00001	10.59
Added Real Estate	843,430	0.00119	765.88
Added Tangibles	102,671	0.0045	462.02
Added Manf Mach	292,878	0.0015	439.32
Added Boats-Atr	14,500	0.00016	2.18
Added Inv/Fin Gds	689,566	0.0005	344.78
Exon. Real Estate	1,046,080	0.00119	1,244.81
Exon. Tangible		0.0045	0.00
Exon. Manf Mach		0.0015	0.00
Exon Inv/Fin Goods	5,385	0.0005	2.69
LSG		0.00122	1,836.11
Penalty			11,477.60
Total			5,425,232.16

CREDITS

Discounts on LSG			36.72
Discounts - Real Estate, ETC.			95,427.71
Exon. Real Estate - Decrease	14,359,070	0.00119	17,087.29
Exon. Tangibles - Decrease	10,182	0.0045	45.73
Exon. Manf Mach		0.0015	0.00
Exon. Inv/Fin Goods	4,707	0.0005	2.35
Exon. Mfg Gp		0.0005	0.00
Exon. Tang		0.00001	0.00
Delinquent Real Estate	25,722,050	0.00119	30,809.24
Delinquent Leasehold		0.00015	0.00
Delinquent Tangibles	832,162	0.0045	2,844.88
Delinquent Tangibles		0.00001	0.00
Delinquent Inv./Fin Goods etc.	11,500	0.0005	5.75
Delinquent Boats-Atr		0.00016	0.00
Total			148,059.48

Payments to State

October	3,794,879.38
November	877,709.81
December	159,572.33
January	120,269.31
February	18,996.82
March	18,022.08
April	60,184.12
May	
Total Paid to State	5,047,633.83

Charges	5,425,232.16
Credits	148,059.48
Commissions	224,364.83
Net Due	5,054,807.85
Refunds	6,973.76
Total Due	5,047,834.10

FISCAL COURT ORDERS

JULY 19, 2022

BOOK 43

REGULAR SESSION OF NELSON FISCAL COURT

PAGE 615

2021-22 COUNTY TAX SETTLEMENT Ramon Pineiroa, NELSON COUNTY SHERIFF

CHARGES

	Assessment
Real Estate	3,436,419,662
Tangible	126,064,990
Inv./Fin Goods	82,120,624
Pub Wh Rs	8,893,242
Boats/Air	1,337,360
Added Real Estate	643,430
Added Tangible	100,623
Added Boats-Air	131,464
Added Inv./Fin Goods	122,442
Exon. Real Estate	1,046,060
Exon. Tangible	
Exon Manf Mech Inv./Fin Goods	5,386
Bank Deposit Taxes	
LSG	
Franchise	
Distilled Spirits	
Penalties	
Total	

	Rate	Collection Amt.
	0.00139	4,776,623.18
	0.00139	175,230.34
	0.00139	114,147.67
	0.00139	12,083.61
	0.00139	1,858.96
	0.00139	894.37
	0.00139	139.87
	0.00139	182.73
	0.00139	170.19
	0.00139	1,464.02
	0.00139	0.00
	0.00139	7.49
		223,332.98
		2,144.70
		118,390.69
		1,228,328.54
		13,085.44
		6,868,074.77

CREDITS

Discounts on LSG	
Discounts - Real Estate, ETC.	
Exon. Real Estate - Decrease	14,359,070
Exon. Tangibles - Decrease	10,162
Exon. Inv./Fin Goods	4,707
Exon. Tangibles - Decrease	
Delinquent Real Estate	25,722,050
Delinquent Tangibles	632,162
Delinquent Inv./Fin Goods	11,600
Delinquent Pub Wh Rs	
Delinquent Boats-Air	
Total	

	0.00139	42.89
	0.00139	114,646.30
	0.00139	19,959.11
	0.00139	14.13
	0.00139	6.64
	0.00139	0.00
	0.00139	35,763.65
	0.00139	878.69
	0.00139	15.99
	0.00139	0.00
	0.00139	0.00
		0.00

171,317.29

Payments to County

Prior to October	8,821.55
October	3,676,926.93
November	1,195,725.60
December	1,067,973.39
January	161,643.94
February	19,983.87
March	24,316.63
April	71,620.87
May	45.13
Total Paid	6,208,860.01

Charges	6,868,074.77
Credits	171,317.29
Commissions	276,112.18
Net Due	6,220,645.30
Refunds	13,551.22
Total Due	6,207,094.08

-234.07

FISCAL COURT ORDERS

JULY 19, 2022

BOOK 43

REGULAR SESSION OF NELSON FISCAL COURT

PAGE 616

2021-22 FIRE ACRES TAX SETTLEMENT Ramon Pineiroa, NELSON COUNTY SHERIFF

CHARGES

	Assessment	Rate	Collection Amt.
Real Estate	27,940	0.02	558.80
Tangible		0.02	0.00
Inv/Fin Goods		0.02	0.00
Added Real Estate		0.02	0.00
Exon. Real Estate		0.02	0.00
Penalties			0.96
Total			569.76

CREDITS

Discounts - Real Estate, ETC.			9.65
Exon. Real Estate - Decrease		0.02	0.00
Delinquent Real Estate	158	0.02	3.16
Delinquent Tangible		0.02	0.00
Delinquent Inv/Fin Goods		0.02	0.00
Total			12.81

Payments to New Hope Fire Dist

October	416.93	Charges	559.76
November	57.94	Credits	12.81
December	32.69	Commissions	23.25
January	13.77	Net Due	523.70
February	0.32	Refunds	523.70
March	1.37		
April	1.69		
May			
Total	523.71		0.01

FISCAL COURT ORDERS

JULY 19, 2022

BOOK 43

REGULAR SESSION OF NELSON FISCAL COURT

PAGE 617

2021-22 E911 SETTLEMENT Ramon Pineiroa, NELSON COUNTY SHERIFF

CHARGES

	Assessment	Rate	Collection Amt.
Real Estate	509,808	1	509,808.00
Tangible		1	0.00
Inv/Fin Goods		1	0.00
Added Real Estate	48	1	48.00
Exon. Real Estate	216	1	216.00
Total			510,072.00

CREDITS

			0.96
Discount			0.96
Exon. Real Estate - Decrease	432	1	432.00
Delinquent Real Estate	5,520	1	5,520.00
Delinquent Tangible		1	0.00
Delinquent Inv/Fin Goods		1	0.00
Total			5,952.96

Payments to New Hope Fire Dist

October	398,592.81	Charges	510,072.00
November	55,821.88	Credits	5,952.96
December	23,826.32	Commissions	5041.19
January	13,955.04	Net Due	499,077.85
February	3,278.88	Refunds	72.00
March	2,542.32		498,005.85
April	3,085.04		
May			
Total	498,982.09		-23.76

FISCAL COURT ORDERS

JULY 19, 2022

BOOK 43

REGULAR SESSION OF NELSON FISCAL COURT

PAGE 618

2021-22 SCHOOL TAX SETTLEMENT Ramon Pineiroa, NELSON COUNTY SHERIFF

CHARGES

	Assessment	Rate	Collection Amt.
Real Estate	2,403,344,848	0.00737	17,712,661.62
Tangible	80,774,781	0.00737	595,309.99
Added Real Estate	453,630	0.00737	3,343.25
Added Tangible		0.0045	0.00
Added Boats-Air/ Manf Mach	14,500	0.00737	106.87
Added Inv/FinGoods,MFG FIP, PUB WH RS		0.0005	0.00
Exon. Real Estate	865,360	0.00737	7,114.70
Exon. Tangibles		0.0045	0.00
Exon. Inv/Fin Gd	5,385	0.00737	39.69
		0.00737	0.00
District change in Tangibles		0.00737	0.00
		0.00737	0.00
LSG			11,371.53
Franchise			472,273.90
Distilled Spirits			4,675,429.62
Penalties			32,018.77
Total			23,509,869.83

CREDITS

Discounts on LSG			227.43
Discounts - Real Estate, ETC.			415,774.06
Exon. Real Estate - Decrease	12,687,570	0.00737	92,770.39
Exon. Tangibles - Decrease	1,190	0.00737	8.77
Exon. Tangibles - Decrease		0.00737	0.00
Delinquent Pub Wh Rs		0.00737	0.00
Delinquent Real Estate	16,279,900	0.00737	119,882.86
Delinquent Tangibles	18,843	0.00737	138.87
Delinquent Inv/Fin Gd		0.00737	0.00
Delinquent Boats-Air		0.00737	0.00
Total			628,902.39

Payments to School

Prior to October	28,982.45
October	14,053,987.08
November	4,435,513.03
December	3,633,925.73
January	562,777.39
February	64,259.88
March	106,247.80
April	90,965.15
May	249.20
Total Paid	22,884,887.87
Commissions Received	503,348.16
Total paid to School	22,381,539.51

Charges	23,509,869.83
Credits	628,902.39
Commissions	503,348.16
Net Due	22,377,409.29
Refunds	32,483.24
Total Due	22,344,946.05

Interest paid to School \$ 656.61

16,593.46

FISCAL COURT ORDERS

JULY 19, 2022

BOOK 43

REGULAR SESSION OF NELSON FISCAL COURT

PAGE 619

2021-22 LIBRARY TAX SETTLEMENT Ramon Pineiroa, NELSON COUNTY SHERIFF

CHARGES

	Assessment	Rate	Collection Amt.
Real Estate	3,438,419,552	0.00088	2,336,765.30
Tangible	128,084,990	0.00088	85,724.19
Inv/Fin Gds	82,120,824	0.00088	56,842.02
Pub Wh Rs	8,693,242	0.00088	5,911.40
Pub Wh Tr	32,687,638	0.00088	22,213.99
Boats-Air	1,337,380	0.00088	909.42
Added Real Estate	843,430	0.00088	437.53
Added Tangible	100,823	0.00088	88.42
Added Boats-Air	14,500	0.00088	9.86
Added Pub Wh RS & TR	132,060	0.00088	89.80
Added Inv/Fin Goods	122,442	0.00088	83.26
Exon. Real Estate	1,046,060	0.00088	711.32
Exon. Tangibles		0.00088	0.00
Exon. Inv/Fin Gds	5,385	0.00088	3.66
Exon. Manf Mach		0.00088	0.00
LSG			1,049.21
Distilled Spirits			648,187.43
Franchise			58,272.83
Penalties			6,401.61
Total			3,222,681.17

CREDITS

Discounts on LSG			20.88
Discounts - Real Estate, ETC.			54,540.93
Exon. Real Estate - Decrease	14,359,070	0.00088	9,764.17
Exon. Tangibles - Decrease	10,162	0.00088	8.81
Exon. Inv/Fin Gd - Decrease	4,707	0.00088	3.20
Delinquent Pub Wh Rs		0.00088	0.00
Delinquent Boats-Air		0.00088	0.00
Delinquent Real Estate	25,722,060	0.00088	17,490.99
Delinquent Tangibles	832,152	0.00088	429.86
Delinquent Inv./Fin Goods	11,500	0.00088	7.82
Total			82,264.87

Payments to Library

Prior to October	4,341.78
October	1,821,723.23
November	637,787.12
December	507,789.87
January	74,181.92
February	9,823.81
March	12,112.13
April	36,036.79
May	22.72
Total Paid	3,002,819.17

Charges	3,222,681.17
Credits	82,264.87
Commissions	133,489.59
Net Due	3,008,947.71
Refunds	4,035.00
Total Due	3,002,912.71

-83.64

FISCAL COURT ORDERS

JULY 19, 2022

BOOK 43

REGULAR SESSION OF NELSON FISCAL COURT

PAGE 620

2021-22 EXTENSION TAX SETTLEMENT Ramon Pinelroa, NELSON COUNTY SHERIFF

CHARGES

	Assessment	Rate	Collection Amt.
Real Estate	3,436,419,552	0.0001	343,641.96
Tangible	126,084,990	0.0001	12,606.50
Inv/Fin Gds	82,120,624	0.0001	8,212.06
Pub Wh Rs	8,993,242	0.0001	899.32
Pub Wh Tr		0.0001	0.00
Added PUB WH RS	116,964	0.0001	11.70
Added Real Estate	643,430	0.0001	64.34
Added Tangible	340,029	0.0001	34.00
Added Inv/Fin Goods		0.0001	0.00
Exon. Real Estate	1,046,060	0.0001	104.81
Exon. Tangibles		0.0001	0.00
Exon. Inv/Fin Gd	5,385	0.0001	0.54
Exon. Manf Mach		0.0001	0.00
LSG			154.29
Distilled Spirits			85,321.88
Franchise			8,536.41
Penalties			941.40
Total			470,498.81

CREDITS

Discounts on LSG			3.09
Discounts - Real Estate, ETC.			7,949.62
Exon. Real Estate - Decrease	14,369,070	0.0001	1,436.91
Exon. Tangibles - Decrease	10,162	0.0001	1.02
Exon. Tangibles - Decrease	4,707	0.0001	0.47
Delinquent Real Estate	25,722,050	0.0001	2,572.21
Delinquent Tangibles	632,162	0.0001	63.22
Delinquent Inv./Fin Goods	11,500	0.0001	1.15
Delinquent Pub Wh Rs		0.0001	0.00
Delinquent Boats/Air		0.0001	0.00
Total			12,026.67

Payments to Extension

Prior to October	631.65
October	284,723.99
November	79,080.03
December	74,676.08
January	10,908.02
February	1,444.88
March	1,766.36
April	5,152.46
May	3.31
Total Paid	438,375.69

Charges	470,498.81
Credits	12,026.67
Commissions	19,484.55
Net Due	438,987.58
Refunds	583.39
Total Due	438,404.19

-28.60

FISCAL COURT ORDERS

JULY 19, 2022

BOOK 43

REGULAR SESSION OF NELSON FISCAL COURT

PAGE 621

2021-22 SOIL CONSERVATION TAX SETTLEMENT Ramon Pinedra, NELSON COUNTY SHERIFF

CHARGES

	Assessment	Rate	Collection Amt.
Real Estate	3,496,419,562	0.000052	178,693.82
Added Real Estate	643,430	0.000052	33.48
Exon. Real Estate (Increase)	1,046,060	0.000052	54.40
LSG			80.23
Franchise			745.87
Penalties			484.81
Total			180,092.58

CREDITS

Discounts - LSG			1.80
Discounts - Real Estate, ETC.			3,123.48
Exon. Real Estate - Decrease	14,359,070	0.000052	746.67
Delinquent Real Estate	25,722,050	0.000052	1,337.55
Total			5,209.30

Payments to Soil Conservation

Prior to October	52.69
October	130,180.02
November	22,012.31
December	6,627.52
January	4,246.66
February	732.09
March	635.67
April	2,855.48
May	
Total Paid	167,142.42

Charges	180,092.58
Credits	5,209.30
Commissions	7,432.55
Net Due	167,450.73
Refunds	299.54
Total Due	167,151.19

-8.77

FISCAL COURT ORDERS

JULY 19, 2022

BOOK 43

REGULAR SESSION OF NELSON FISCAL COURT

PAGE 622

2021-22 NORTHEAST NELSON FIRE TAX SETTLEMENT Ramon Pineiroa, NELSON COUNTY SHERIFF

CHARGES

	Assessment	Rate	Collection Amt.
Real Estate	280,088,142	0.001	280,088.14
Exon. Real Estate	2,970	0.001	2.97
Added Real Estate	64,200	0.001	64.20
Franchise			526.37
Penalties			815.63
District Change In		0.001	0.00
Total			281,507.31

CREDITS

Discounts - Real Estate, ETC.			4,671.16
Exon. Real Estate - Decrease	2,006,716	0.001	2,006.72
Delinquent Real Estate	2,130,805	0.001	2,130.81
Total			8,608.67

Payments to Northeast Nelson

Prior to October			
October	203,498.10		
November	29,282.19		
December	21,041.63		
January	8,431.87		
February	973.32		
March	1,906.38		
April	2,840.00		
May			
Total	288,972.27		

Charges	281,507.31
Credits	8,608.67
Commissions	2,728.98
Net Due	288,971.86
Refunds	999.39
	288,972.27

\$0.00

FISCAL COURT ORDERS

JULY 19, 2022

BOOK 43

REGULAR SESSION OF NELSON FISCAL COURT

PAGE 623

2021-22 Nelson County Fire & Rescue TAX SETTLEMENT Ramon Pineiroa, NELSON COUNTY SHERIFF

CHARGES

	Assessment	Rate	Collection Amt.
Real Estate	566,231	1	566,231.00
Exon. Real Estate	480	1	480.00
Added Bills	60	1	60.00
Penalties			1,158.20
Total			567,927.20

CREDITS

Discounts - Real Estate, ETC.			9,999.26
Exon. Real Estate - Decrease	300	1	300.00
Delinquent Real Estate	5666	1	5,665.00
Total			15,964.26

Payments to BNC Fire

October	443,774.77
November	54,789.19
December	26,315.19
January	12,831.88
February	2,895.75
March	2,620.73
April	3,098.21
May	
Total	546,325.73

Charges	567,927.20
Credits	15,964.26
Commissions	5,619.63
Net Due	546,443.31
Refunds	117.60
	546,325.71

0.02

FISCAL COURT ORDERS

JULY 19, 2022

BOOK 43

REGULAR SESSION OF NELSON FISCAL COURT

PAGE 624

2021-22 BOSTON FIRE TAX SETTLEMENT Ramon Pineiroa, NELSON COUNTY SHERIFF

CHARGES

	Assesment	Rate	Collection Amt.
Real Estate	34,900	1	34,900.00
Added Real Estate			
Exon. Real Estate			
Penalties			130.00
Total			35,030.00

CREDITS

Discounts - Real Estate, ETC.			566.00
Exon. Real Estate - Decrease	100	1	100.00
Delinquent Real Estate	800	1	800.00
Total			1,466.00

Payments to Boston Fire Dist

October	25,419.24
November	3,621.42
December	1,831.50
January	1,588.85
February	160.88
March	326.70
April	289.78
May	
Total	33,228.37

Charges	35,030.00
Credits	1,466.00
Commissions	335.64
Net Due	33,228.36
Refunds	0
	33,228.36
	0.01

FISCAL COURT ORDERS

JULY 19, 2022

BOOK 43

REGULAR SESSION OF NELSON FISCAL COURT

PAGE 625

2021-22 ROLLING FORK FIRE TAX SETTLEMENT Ramon Pinelroa, NELSON COUNTY SHERIFF

CHARGES

	Assessment	Rate	Collection Amt.
Real Estate	47,370	1	47,370.00
Added Bills		1	30.00
Exon. Real Estate		1	0.00
Penalties			172.50
Total			47,572.50

CREDITS

Discounts - Real Estate, ETC.			789.20
Exon. Real Estate - Decrease	180	1	180.00
Delinquent Real Estate	860	1	860.00
Total			1,809.20

Payments to Rolling Fork Fire Dist

October	34,808.45		
November	4,312.44		
December	3,693.11		
January	1,784.18		
February	384.82		
March	281.38		
April	522.72		
May			
Total	45,444.88		

Charges			47,572.50
Credits			1,809.20
Commissions			459.63
Net Due			45,503.67
Refunds			58.80
Total Due			45,444.87
			<u>0.01</u>

FISCAL COURT ORDERS

JULY 19, 2022

BOOK 43

REGULAR SESSION OF NELSON FISCAL COURT

PAGE 626

2021-22 NEW HOPE FIRE TAX SETTLEMENT Ramon Pinalroa, NELSON COUNTY SHERIFF

CHARGES

	Assessment		Rate	Collection Amt.
Real Estate	42,220		1	42,220.00
Added Real Estate				
Exon. Real Estate				
Penalties				251.00
Total				42,471.00

CREDITS

Discounts - Real Estate, ETC.				814.00
Exon. Real Estate - Decrease	110		1	110.00
Delinquent Real Estate	2400		1	2,400.00
Total				3,124.00

Payments to New Hope Fire Dist

October	27,340.24			
November	4,882.30			
December	2,712.60			
January	2,246.81			
February	836.85			
March	382.04			
April	664.29			
May				
Total	38,875.13			0.00

Charges	42,471.00
Credits	3,124.00
Commissions	393.47
Net Due	38,953.63
Refunds	78.40
	38,875.13

FISCAL COURT ORDERS

JULY 19, 2022

BOOK 43

REGULAR SESSION OF NELSON FISCAL COURT

PAGE 627

2021-22 BLOOMFIELD CITY TAX SETTLEMENT Ramon Pineiroa, NELSON COUNTY SHERIFF

CHARGES

	Assessment	Rate	Collection Amt.
Real Estate	45,158,438	0.00322	145,413.39
Tangible	484,160	0.00322	1,541.94
Inv/Fin Goods	2,284,223	0.00322	7,588.18
Added Real Estate		0.00322	0.00
Exon. Real Estate			
Franchise			5,287.53
Penalties			484.86
Total			180,285.91

CREDITS

Discounts - Real Estate, ETC.			2,708.75
Exon. Real Estate - Decrease	81,000	0.00322	260.82
Delinquent Real Estate	332,600	0.00322	1,070.97
Delinquent Tangible		0.00322	0.00
Delinquent Inv/Fin Goods		0.00322	0.00
Total			4,040.54

Payments to City of Bloomfield

October	112,504.84	Charges	180,285.91
November	17,448.00	Credits	4,040.54
December	8,357.51	Commissions	6840.86
January	8,243.09	Net Due	148,614.51
February	373.97	Refunds	148,614.51
March	770.93		
April	1,915.18		
May			
Total	149,614.50		-0.01

FISCAL COURT ORDERS

JULY 19, 2022

BOOK 43

REGULAR SESSION OF NELSON FISCAL COURT

PAGE 628

SUPPLEMENTAL MEMORANDUM OF AGREEMENT

THIS SUPPLEMENTAL MEMORANDUM OF AGREEMENT (“Supplemental MOA”) is made and entered into on this 19 day of July 2022 (the “Effective Date”) by and among the Nelson Fiscal Court (the “Fiscal Court”), the City of Bardstown, Kentucky (“Bardstown”), and North Nelson Water District (the “District”).

WITNESSETH:

WHEREAS, the Fiscal Court, Bardstown, and the District previously executed a Memorandum of Agreement (“MOA”), which has an Effective Date of December 21, 2021;

WHEREAS, the purpose of the MOA is to facilitate the construction of a large diameter water transmission main along Kentucky Highway 245 to serve as a regional transmission water supply line. This regional project is identified in the MOA as the “Nelson County Water Supply Project” or the “Project”;

WHEREAS, the Parties have been seeking additional grants to supplement the funds itemized and allocated for the Project in the MOA;

WHEREAS, the Parties’ efforts have been exceptionally successful;

WHEREAS, the Fiscal Court has been allocated the sum of \$10,000,000 by the Kentucky General Assembly for this Project. This allocation is contained in House Bill 1, which is the State Executive Branch Budget for Fiscal Years 2022-

FISCAL COURT ORDERS

JULY 19, 2022

BOOK 43

REGULAR SESSION OF NELSON FISCAL COURT

PAGE 629

2023 and 2023-2024, adopted by the 2022 General Assembly, and it shall be referenced as the "2022 State Budget Allocation";

WHEREAS, as set forth in House Bill 1, Section 1, Part I, A. General Government, 5(6)(d), the purpose of the 2022 State Budget Allocation is for "regional water supply infrastructure projects," including "regional water supply lines";

WHEREAS, the Parties desire for the 2022 State Budget Allocation to be utilized as part of the funding for the Project;

WHEREAS, it is mutually advantageous for the Fiscal Court, Bardstown, and the District to enter into this Supplemental MOA; and

WHEREAS, the Parties desire to supplement the MOA as hereinafter provided.

NOW, THEREFORE, in consideration of the mutual covenants of the parties hereto, it is hereby agreed as follows:

1. **Recitals.** The facts, recitals, and statements contained in the MOA and in the foregoing preamble of this Supplemental MOA are true and correct, and are hereby affirmed and incorporated as a part of this Supplemental MOA.

2. **MOA Still in Effect.** Each and every provision of the MOA, as supplemented by this Supplemental MOA, shall continue to remain in full force and effect.

FISCAL COURT ORDERS

JULY 19, 2022

BOOK 43

REGULAR SESSION OF NELSON FISCAL COURT

PAGE 630

3. **Additional Fiscal Court Contribution.** In addition to the contributions of the Fiscal Court set forth in paragraph 3 of the MOA, the Fiscal Court shall also contribute the 2022 State Budget Allocation in the amount of \$10,000,000 to the Project.

4. **Water Main Size.** The water transmission main shall either be a 20-inch or a 24-inch diameter ductile iron pipe based upon the bids received and the available Project funding. Both diameter sizes shall be bid.

5. **Bid Alternates.** The Project shall be advertised for bid with the following bid alternates or options:

- A. Bid Option 1: 20-inch diameter water transmission main extending from Kentucky Highway 1604 to Houghlin Funeral Home.
- B. Bid Option 1-A: 24-inch diameter water transmission main extending from Kentucky Highway 1604 to Houghlin Funeral Home.
- C. Bid Option 2: 20-inch diameter water transmission main extending from Houghlin Funeral Home to Bardstown's Withrow Court Water Storage Tank (the "Bardstown Interconnect Portion of Project").
- D. Bid Option 2-A: 24-inch diameter water transmission main extending from Houghlin Funeral Home to Bardstown's Withrow Court Water Storage Tank (the "Bardstown Interconnect Portion of Project").

FISCAL COURT ORDERS

JULY 19, 2022

BOOK 43

REGULAR SESSION OF NELSON FISCAL COURT

PAGE 631

6. **Order of Funding.** All funds described in the MOA and in this Supplemental MOA shall be prioritized and spent in the following order:

- A. First: Fully fund Bid Option 1 or 1-A.
- B. Second: Fund Bid Option 2 or 2-A. Any grants for the Water infrastructure projects in this MOU that are applicable to any cost sharing agreements related to local Distillery expansions will be used to lower those costs by the appropriate percentages agreed upon by those agreements.
- C. Third: Any remaining funds shall be allocated to the Bardstown East Side Water System Improvements.

7. **Cooperation.** Each of the Parties agree to cooperate with the other parties in the timely execution of any documents necessary to effectuate the provisions of the MOA and this Supplemental MOA.

8. **Assignment and Amendment.**

A. This Supplemental MOA and the rights of the Fiscal Court, or Bardstown, or the District shall not be conveyed, assigned, or transferred to any other person or entity without the prior written consent of all Parties.

B. This Supplemental MOA shall not be amended or modified unless such amendment or modification is in writing and signed by all Parties.

9. **Entirety.** The Parties further agree that the MOA, as supplemented by this Supplemental MOA, now constitutes the entire understanding of the Fiscal

FISCAL COURT ORDERS

JULY 19, 2022

BOOK 43

REGULAR SESSION OF NELSON FISCAL COURT

PAGE 632

Court, Bardstown, and the District with respect to the transaction contemplated therein.

10. Counterparts. This Supplemental MOA may be executed in multiple counterparts by the Parties hereto. All of such counterparts shall be construed as if all signatures were appended to one document. The Parties hereto agree that a facsimile or e-mail of a counterpart of this signed Supplemental MOA constitutes an original counterpart, and shall be a valid and binding document for all legal and other purposes.

11. Severability. The invalidity or unenforceability of any provision of this Supplemental MOA shall not affect the validity or enforceability of any other provision hereof, and any such invalid or unenforceable provision shall be deemed to be severable.

IN WITNESS WHEREOF, this Supplemental MOA has been executed in multiple counterparts, each of which is deemed to be an original, by the duly authorized officers and officials of the Parties pursuant to authority granted by the governing body of each respective Party, as of its Effective Date.

[signature pages to follow]

FISCAL COURT ORDERS

JULY 19, 2022

BOOK 43

REGULAR SESSION OF NELSON FISCAL COURT

PAGE 633

NELSON COUNTY FISCAL COURT

BY:



Dean Watts, County Judge/Executive

ATTEST:



Jeanette Sidebottom, Nelson County Clerk

FISCAL COURT ORDERS

JULY 19, 2022

BOOK 43

REGULAR SESSION OF NELSON FISCAL COURT

PAGE 634

CITY OF BARDSTOWN, KENTUCKY

BY: _____
J. Richard Heaton, Mayor

ATTEST:

Gary Little, City Clerk

FISCAL COURT ORDERS

JULY 19, 2022

BOOK 43

REGULAR SESSION OF NELSON FISCAL COURT

PAGE 635

NORTH NELSON WATER DISTRICT

BY: _____
Nicky Rapier, Chairman

ATTEST:

Don Mudd, Secretary

FISCAL COURT ORDERS

JULY 19, 2022

BOOK 43

REGULAR SESSION OF NELSON FISCAL COURT

PAGE 636

MEMORANDUM OF AGREEMENT AND CONTRACT

This Agreement, entered into by and between the City of New Haven and the Nelson County Fiscal Court on this 19 day of July, 2022:

WHEREAS, Nelson County has received certain funds under the American Rescue Plan Act for the construction of certain capital projects within the County:

WHEREAS, Nelson County and the City of New Haven would mutually benefit from certain capital improvements to the City of New Haven's sewer system including but not limited to engineering, design and construction of said improvements;

NOW, THEREFORE, for the consideration described herein, the sufficiency and receipt of which is hereby acknowledged, the Nelson County Fiscal Court agrees to provide up to \$200,000 of ARPA Funds to the City of New Haven to assist in said improvements.

This Agreement entered into this the 19 day of July, 2022

by: Dean Watts
Dean Watts, Nelson County Fiscal Court

by: Tessie Cecil
Tessie Cecil, Mayor City of New Haven

FISCAL COURT ORDERS

JULY 19, 2022

BOOK 43

REGULAR SESSION OF NELSON FISCAL COURT

PAGE 637



OFFICE OF THE GOVERNOR DEPARTMENT FOR LOCAL GOVERNMENT

Andy Beshear
Governor

100 Airport Road, Third Floor
Frankfort, Kentucky 40601
Phone: (502) 573-2382
Fax: (502) 227-8691
www.kydlgweb.ky.gov

Dennis Keene
Commissioner

MEMORANDUM

TO: County Treasurers

FROM: Robert O. Brown *R.B.*
State Local Finance Officer

DATE: April 21, 2022

SUBJECT: SB 135 – County Clerk Permanent Storage Fees

Senate Bill 135 (22 Regular Session) was signed into law by Governor Beshear and will go into effect July 2022. This bill will allow county clerks to receive a \$10 reimbursement for permanent storage of records. This fee must be accumulated and transferred to the fiscal court each month. The fiscal court must maintain these fees in a separate bank account and account for them in a separate fund. The monies accumulated from this fee shall be held in perpetuity by the fiscal court for the county clerk's exclusive use for items needed to maintain permanent storage.

I am recommending that you utilize any Special Fund Code within the range outlined in our budget manual (75-88). Please utilize Receipt Code 4731 – Miscellaneous Revenues – County Clerk Permanent Storage Fees. When your clerks submit claims for payment relative to permanent storage, please expend by using the appropriate expenditure code in our budget manual.

I know many of you have or currently are preparing your new fiscal year budgets. Please know that these monies will not be realized until after the start of the new fiscal year. Thus, if not included in your budget you must perform a budget amendment. Thank you for your attention concerning this matter. If you have any questions, please feel free to reach out to your local government advisor here at DLG.

TEAM
KENTUCKY

An Equal Opportunity Employer M/F/D

FISCAL COURT ORDERS

JULY 19, 2022

BOOK 43

REGULAR SESSION OF NELSON FISCAL COURT

PAGE 638

UNOFFICIAL COPY

22 RS SB 135.GA

1 AN ACT relating to county clerks.

2 *Be it enacted by the General Assembly of the Commonwealth of Kentucky:*

3 →SECTION 1. A NEW SECTION OF KRS CHAPTER 67 IS CREATED TO
4 READ AS FOLLOWS:

5 (1) As used in this section:

6 (a) "Recorded instrument" means any document relating to real property,
7 personal property, and any property for which a Kentucky certificate of title
8 has been issued, including but not limited to deeds and mortgages; and

9 (b) "Portal" means a Web site or online database that:

10 1. Is readily accessible by the public to provide remote online access to
11 recorded instruments;

12 2. Has a network security device that monitors incoming and outgoing
13 network traffic and determines whether to allow or block specific
14 traffic based on a defined set of security rules; and

15 3. Has a system which provides for backup copies of recorded
16 instruments to be securely stored.

17 (2) By June 30, 2023, all county clerks shall provide and maintain the portal that
18 allows a person to electronically file any recorded instrument.

19 (3) (a) By June 30, 2024, each county clerk shall provide and maintain a portal
20 that contains the following recorded instruments:

21 1. Filed on or after June 30, 1994:

22 a. Deeds;

23 b. Mortgages;

24 c. Fixture filings under the Uniform Commercial Code;

25 d. Plats of subdivided property;

26 e. All covenants, conditions, and restrictions that relate to real
27 property;

FISCAL COURT ORDERS

JULY 19, 2022

BOOK 43

REGULAR SESSION OF NELSON FISCAL COURT

PAGE 639

UNOFFICIAL COPY

22 RS SB 135/GA

- 1 f. Easements;
2 g. Leases or memorandum of leases;
3 h. Powers of attorney;
4 i. Land contracts;
5 j. Wills; and
6 k. Affidavits that affect or clarify the title to property;
7 2. Filed on or after June 30, 2004, child support liens;
8 3. Filed on or after June 30, 2009;
9 a. Judgment liens;
10 b. Recoupment and unemployment liens; and
11 c. Lis pendens notices;
12 4. Filed on or after June 30, 2014;
13 a. Federal and state tax liens; and
14 b. Civil penalty liens;
15 5. Filed on or after June 30, 2019;
16 a. Homeowner's association or condominium liens; and
17 b. Bail bonds.
18 (b) By June 30, 2026, each county clerk shall provide and maintain a portal
19 that contains the following recorded instruments filed on or after June 30,
20 1966, but before June 30, 1994:
21 1. Deeds;
22 2. Mortgages;
23 3. Fixture filings under the Uniform Commercial Code;
24 4. Plats of subdivided property;
25 5. All covenants, conditions, and restrictions that relate to real property;
26 6. Easements;
27 7. Leases or memorandum of leases;

FISCAL COURT ORDERS

JULY 19, 2022

BOOK 43

REGULAR SESSION OF NELSON FISCAL COURT

PAGE 640

UNOFFICIAL COPY

22 RS SB 135/GA

- 1 8. Powers of attorney;
2 9. Land contracts;
3 10. Wills; and
4 11. Affidavits that affect or clarify the title to property.
5 (4) (a) Any fee charged by the county clerk for access to electronic copies of
6 recorded instruments shall not exceed the actual cost of providing and
7 maintaining the portal.
8 (b) If a county clerk contracts with an outside vendor to provide and maintain a
9 portal required under this section, actual costs may include:
10 1. Development and maintenance of a portal that provides access to
11 recorded instruments;
12 2. Personnel costs for companies that employ staff to support county
13 clerks;
14 3. Maintenance of cybersecurity credentials; and
15 4. Insurance premiums.
16 (5) A county clerk may redact Social Security numbers from electronic copies of
17 recorded instruments and other personal information from recorded instruments
18 upon request from a law enforcement agency or judicial officer.
19 ➔Section 2. KRS 64.012 is amended to read as follows:
20 (1) The county clerk shall receive for the following services the following fees:
21 (a) 1. Recording and indexing of a:
22 a. Deed of trust or assignment for the benefit of creditors;
23 b. Deed;
24 c. Deed of assignment;
25 d. File-stamped copy of documents set forth in KRS 14A.2-040(1) or
26 (2) that have been filed first with the Secretary of State;
27 e. Real estate option;

FISCAL COURT ORDERS

JULY 19, 2022

BOOK 43

REGULAR SESSION OF NELSON FISCAL COURT

PAGE 641

UNOFFICIAL COPY

22 RS SB 135/GA

- 1 f. Power of attorney;
- 2 g. Revocation of power of attorney;
- 3 h. Lease which is recordable by law;
- 4 i. Deed of release of a mortgage or lien under KRS 382.360;
- 5 j. United States lien;
- 6 k. Release of a United States lien;
- 7 l. Release of any recorded encumbrance other than state liens;
- 8 m. Lis pendens notice concerning proceedings in bankruptcy;
- 9 n. Lis pendens notice;
- 10 o. Mechanic's and artisan's lien under KRS Chapter 376;
- 11 p. Assumed name;
- 12 q. Notice of lien issued by the Internal Revenue Service;
- 13 r. Notice of lien discharge issued by the Internal Revenue Service;
- 14 s. Original, assignment, amendment, or continuation financing
- 15 statement;
- 16 t. Making a record for the establishment of a city, recording the plan
- 17 or plat thereof, and all other service incident;
- 18 u. Survey of a city, or any part thereof, or any addition to or
- 19 extensions of the boundary of a city;
- 20 v. Recording with statutory authority for which no specific fee is set,
- 21 except a military discharge;
- 22 w. Will or other probate document pursuant to KRS Chapter 392 or
- 23 394;
- 24 x. Court ordered name change pursuant to KRS Chapter 401;
- 25 y. Land use restriction according to KRS 100.3681; and
- 26 z. Filing with statutory authority for which no specific fee is set.
- 27 For all items in this subsection if the entire thereof does not exceed

FISCAL COURT ORDERS

JULY 19, 2022

BOOK 43

REGULAR SESSION OF NELSON FISCAL COURT

PAGE 642

UNOFFICIAL COPY

22 RS SB 135/GA

1	five (5) pages	\$33.00
2	And, for all items in this subsection exceeding five (5) pages,	
3	for each additional page	\$3.00
4	And, for all items in this subsection for each additional reference	
5	relating to same instrument	\$4.00
6	2. The thirty-three dollar (\$33) fee imposed by this subsection shall be	
7	divided as follows:	
8	a. Twenty-seven dollars (\$27) shall be retained by the county clerk;	
9	and	
10	b. Six dollars (\$6) shall be paid to the affordable housing trust fund	
11	established in KRS 198A.710 and shall be remitted by the county	
12	clerk within ten (10) days following the end of the quarter in which	
13	the fee was received. Each remittance to the affordable housing	
14	trust fund shall be accompanied by a summary report on a form	
15	prescribed by the Kentucky Housing Corporation.	
16	(b) For noting a security interest on a certificate of title pursuant to	
17	KRS Chapter 186A	\$12.00
18	(c) For filing the release of collateral under a financing statement	
19	and noting same upon the face of the title pursuant to KRS Chapter	
20	186 or 186A	\$5.00
21	(d) Filing or recording state tax or other state liens	
22	(e) Filing release of a state tax or other state lien	
23	(f) Acknowledging or notarizing any deed, mortgage, power of attorney,	
24	or other written instrument required by law for recording and certifying	
25	same	\$5.00
26	(g) Recording plats, maps, and surveys, not exceeding 24 inches by	
27	36 inches, per page	\$40.00

FISCAL COURT ORDERS

JULY 19, 2022

BOOK 43

REGULAR SESSION OF NELSON FISCAL COURT

PAGE 643

UNOFFICIAL COPY

22 RS SB 135 GA

1	(h) Recording a bond, for each bond	\$10.00
2	(i) Each bond required to be taken or prepared by the clerk	\$4.00
3	(j) Copy of any bond when ordered	\$3.00
4	(k) Administering an oath and certificate thereof	\$5.00
5	(l) Issuing a license for which no other fee is fixed by law	\$8.00
6	(m) Issuing a solicitor's license	\$15.00
7	(n) Marriage license, indexing, recording, and issuing certificate thereof	\$26.50
8	(o) Every order concerning the establishment, changing, closing, or	
9	discontinuing of roads, to be paid out of the county levy when	
10	the road is established, changed, closed, or discontinued, and by	
11	the applicant when it is not	\$3.00
12	(p) Registration of licenses for professional persons required to register	
13	with the county clerk	\$10.00
14	(q) Certified copy of any record	\$5.00
15	Plus fifty cents (\$.50) per page after three (3) pages	
16	(r) Filing certification required by KRS 65.070(2)(a)	\$5.00
17	(s) Filing notification and declaration and petition of candidates	
18	for Commonwealth's attorney	\$200.00
19	(t) Filing notification and declaration and petition of candidates for county	
20	and independent boards of education	\$20.00
21	(u) Filing notification and declaration and petition of candidates for	
22	boards of soil and water conservation districts	\$20.00
23	(v) Filing notification and declaration and petition of candidates for	
24	other office	\$50.00
25	(w) Filing declaration of intent to be a write-in candidate for office	\$50.00
26	(x) Filing petitions for elections, other than nominating petitions	\$50.00
27	(y) Notarizing any signature, per signature	\$2.00

FISCAL COURT ORDERS

JULY 19, 2022

BOOK 43

REGULAR SESSION OF NELSON FISCAL COURT

PAGE 644

UNOFFICIAL COPY

22 RS SB 135 GA

- 1 (z) Filing bond for receiving bodies under KRS 311.310\$10.00
- 2 (aa) Noting the assignment of a certificate of delinquency and recording
- 3 and indexing the encumbrance under KRS 134.126 or 134.127\$27.00
- 4 (ab) Filing a going-out-of-business permit under KRS 365.445\$50.00
- 5 (ac) Filing a renewal of a going-out-of-business permit under KRS 365.445 \$50.00
- 6 (ad) Filing and processing a transient merchant permit under KRS 365.680 . \$25.00
- 7 (ae) Recording and indexing a real estate mortgage:
- 8 1. For a mortgage that does not exceed thirty (30) pages\$63.00
- 9 2. And, for a mortgage that exceeds thirty (30) pages, for each additional
- 10 page\$3.00
- 11 (af) Filing or recording a lien or release of lien by a consolidated local
- 12 government, urban-county government, unified local government, or city of
- 13 any class\$20.00
- 14 (2) The sixty-three dollar (\$63) fee imposed by subsection (1)(ae) of this section shall
- 15 be divided as follows:
- 16 (a) Fifty-seven dollars (\$57) shall be retained by the county clerk; and
- 17 (b) Six dollars (\$6) shall be paid to the affordable housing trust fund established
- 18 in KRS 198A.710 and shall be remitted by the county clerk within ten (10)
- 19 days following the end of the quarter in which the fee was received. Each
- 20 remittance to the affordable housing trust fund shall be accompanied by a
- 21 summary report on a form prescribed by the Kentucky Housing Corporation.
- 22 (3) (a) For services related to the permanent storage of records listed in paragraphs
- 23 (a), (g), (n), and (ae) of subsection (1) of this section, the clerk shall be
- 24 entitled to receive a reimbursement of ten dollars (\$10).
- 25 (b) This fee shall:
- 26 1. Not be paid annually to the fiscal court under KRS 64.152;
- 27 2. Not be paid to the Finance and Administration Cabinet under KRS

FISCAL COURT ORDERS

JULY 19, 2022

BOOK 43

REGULAR SESSION OF NELSON FISCAL COURT

PAGE 645

UNOFFICIAL COPY

22 RS SB 135/GA

- 1 64.345:
- 2 3. Be accumulated and transferred to the fiscal court or the legislative
- 3 body of a consolidated local government or an urban-county
- 4 government on a monthly basis within ten (10) days following the end
- 5 of the month;
- 6 4. Be maintained by the fiscal court or the legislative body of a
- 7 consolidated local government or an urban-county government in a
- 8 separate bank account and accounted for in a separate fund; and
- 9 5. Not lapse to the general fund of the county, consolidated local
- 10 government, or urban-county government.
- 11 (c) The moneys accumulated from this fee shall be held in perpetuity by the
- 12 fiscal court or the legislative body of a consolidated local government or an
- 13 urban-county government for the county clerk's exclusive use for:
- 14 1. Equipment related to the permanent storage of and access to records,
- 15 including deed books, binders, shelves, microfilm equipment, and
- 16 fireproof equipment;
- 17 2. Hardware for the permanent storage of and access to records,
- 18 including computers, servers, and scanners;
- 19 3. Software for the permanent storage of and access to records, including
- 20 vendor services and consumer subscription fees;
- 21 4. Personnel costs for the permanent storage of and access to records,
- 22 including overtime costs for personnel involved in the digitization of
- 23 records; and
- 24 5. Cloud storage and cybersecurity services for the permanent storage of
- 25 and access to records.
- 26 (d) Notwithstanding KRS 68.275, claims by a county clerk that are for the
- 27 approved expenditures in paragraph (c) of this subsection shall be paid by

FISCAL COURT ORDERS

JULY 19, 2022

BOOK 43

REGULAR SESSION OF NELSON FISCAL COURT

PAGE 646

UNOFFICIAL COPY

22 RS SB 135 GA

1 the county judge/executive or the chief executive officer of a consolidated
2 local government or an urban-county government by a warrant drawn on
3 the fund and co-signed by the treasurer of the county, consolidated local
4 government, or urban-county government.

5 (e) No later than July 1 of each year, each county fiscal court or legislative
6 body of a consolidated local government or an urban-county government
7 shall submit a report to the Legislative Research Commission detailing the
8 receipts, expenditures, and any amounts remaining in the fund.

9 ➔ Section 3. KRS 142.010 is amended to read as follows:

- 10 (1) The following taxes shall be paid:
- 11 (a) A tax of four dollars and fifty cents (\$4.50) on each marriage license;
- 12 (b) A tax of four dollars (\$4) on each power of attorney to convey real or personal
- 13 property;
- 14 (c) A tax of four dollars (\$4) on each mortgage, financing statement, or security
- 15 agreement and on each notation of a security interest on a certificate of title
- 16 under KRS 186A.190;
- 17 (d) A tax of four dollars (\$4) on each conveyance of real property; and
- 18 (e) A tax of four dollars (\$4) on each lien or conveyance of coal, oil, gas, or other
- 19 mineral right or privilege.
- 20 (2) The tax imposed by this section shall be collected by each county clerk as a
- 21 prerequisite to the issuance of a marriage license or the original filing of an
- 22 instrument subject to the tax. Subsequent assignment of the original instrument
- 23 shall not be cause for additional taxation under this section. This section shall not
- 24 be construed to require any tax upon a deed of release of a lien retained in a deed or
- 25 mortgage.
- 26 (3) Taxes imposed under this section shall be reported and paid to the Department of
- 27 Revenue by each county clerk within ten (10) days following the end of the calendar

FISCAL COURT ORDERS

JULY 19, 2022

BOOK 43

REGULAR SESSION OF NELSON FISCAL COURT

PAGE 647

UNOFFICIAL COPY

22 RS SB 135/GA

1 month in which instruments subject to tax are filed or marriage licenses issued.
2 Each remittance shall be accompanied by a summary report on a form prescribed by
3 the department.

4 (4) Any county clerk who violates any of the provisions of this section shall be subject
5 to the uniform civil penalties imposed pursuant to KRS 131.180. In every case, any
6 tax not paid on or before the due date shall bear interest at the tax interest rate as
7 defined in KRS 131.010(6) from the date due until the date of payment.

8 (5) (a) One dollar (\$1) of the amount collected under each paragraph of subsection
9 (1) of this section shall be placed in an agency fund in the Department for
10 Libraries and Archives to be used exclusively for the purpose of preserving
11 and retaining public records by continuing the local records grant program
12 active in the Department for Libraries and Archives. ~~[The budgeted amount of
13 funds allocated to the grant program in the fiscal year 2005-2006 departmental
14 budget shall not be reduced in future years, and shall be increased annually by
15 this additional revenue to be used exclusively for the grants program.]~~

16 (b) Ninety percent (90%) of all funds allocated to the Department for Libraries
17 and Archives under paragraph (a) of this subsection for the local records
18 grant program shall be set aside for grants to county clerks and distributed
19 annually, except as provided in paragraph (c) of this subsection.

20 (c) If there are insufficient grant applications from county clerks for the
21 Department for Libraries and Archives to distribute ninety percent (90%) of
22 all funds allocated under paragraph (a) of this subsection, the Department
23 for Libraries and Archives may grant those funds to other agencies.

24 ➔SECTION 4. A NEW SECTION OF KRS CHAPTER 64 IS CREATED TO
25 READ AS FOLLOWS:

26 (1) (a) A county clerk in a county containing a population of less than seventy
27 thousand (70,000) may be entitled to receive an advancement to:

FISCAL COURT ORDERS

JULY 19, 2022

BOOK 43

REGULAR SESSION OF NELSON FISCAL COURT

PAGE 648

UNOFFICIAL COPY

22 RS SB 135 GA

- 1 1. Defray necessary official expenses; and
2 2. Supplement the payment of the salaries of the county clerk or the
3 county clerk's deputies and assistants.
4 **(b) 1. The secretary of the Finance and Administration Cabinet shall, on the**
5 first day of each calendar month, determine the necessary amount that
6 may be advanced to the county clerk.
7 2. The advance shall be the lesser of:
8 a. One-twelfth (1/12) of the total fees collected by the county clerk
9 for the preceding year; or
10 b. Sixty thousand (\$60,000) dollars per month.
11 **(c) When approved by the secretary of the Finance and Administration**
12 Cabinet, a warrant shall be drawn on the State Treasury in favor of the
13 county clerk for such advancement.
14 **(d) Funds advanced under this section shall be repaid by the county clerk to**
15 whom the funds were advanced no later than the close of the calendar year
16 in which the funds were advanced. If the funds are not timely repaid, then
17 the county clerk in his or her official capacity or the surety for the county
18 clerk shall be liable to the Commonwealth.
19 **(2) If a county clerk makes a request for funds from the State Treasury to defray**
20 necessary official expenses, the county clerk shall not be required to submit a
21 detailed statement of his or her personal assets and liabilities as a condition of the
22 application process.
23 **(3) The Finance and Administration Cabinet shall promulgate administrative**
24 regulations in accordance with KRS Chapter 13A as necessary to implement the
25 provisions of this section.

FISCAL COURT ORDERS

JULY 19, 2022

BOOK 43

REGULAR SESSION OF NELSON FISCAL COURT

PAGE 649

NELSON COUNTY FISCAL COURT RESOLUTION NO. 2 2022

RESOLUTION OF CONSENT TO ANNEXATION OF DEAN WATTS PARK BY CITY OF BARDSTOWN, KENTUCKY

BE IT RESOLVED by the Nelson County, Kentucky Fiscal Court ("Fiscal Court") on this 19th day of July, 2022 in a public meeting as follows:

WHEREAS the Fiscal Court² has received a written request from the City of Bardstown ("City") for the Fiscal Court to consent to annexation of real property constituting the Dean Watts Park ("Park") pursuant to KRS Chapter 81A;

WHEREAS, the Fiscal Court being aware of its discretion as to whether to consent to such annexation under authority of KRS 81A.412 and its Home Rule powers, has deliberated on the matter; and hereby CONSENTS to such annexation consistent with this Resolution;

WHEREAS, the Fiscal Court finds such annexation is in the interest of Nelson County, Kentucky and the health, safety, and welfare of its citizens;

WHEREAS, this consent to annexation of the Park is for annexation of real property more particularly described in a deed to Fiscal Court and/or Nelson County dated Dec 1, 1995 AND Dec 16, 1997 and recorded in DEED BOOKS 326/69 AND 345/573 in the Office of the Nelson County, Kentucky Clerk;

WHEREAS, this consent to annexation does not require deed or lease of any real property or transfer of personal property to the City or any other person or entity in that Fiscal Court shall retain ownership of the Park and any rights and obligations as to its operations subsequent to the contemplated annexation;

FISCAL COURT ORDERS

JULY 19, 2022

BOOK 43

REGULAR SESSION OF NELSON FISCAL COURT

PAGE 650

WHEREAS, this consent to annexation does not constitute any restriction on Fiscal Court's sale, lease, or other alienation of the Park or personal property thereon in the future;

WHEREAS, the Fiscal Court is aware of no person residing in or being registered to vote as a resident of the Park;

WHEREAS, the Fiscal Court recognizes the City has requested this Consent to Annexation to be irrevocable because the City will incur survey and other costs in connection with the annexation and would be damaged if the Fiscal Court later attempted to revoke or otherwise alter its consent and so the Fiscal Court agrees to the City's request;

WHEREAS, the Fiscal Court does not agree to make any payments, compensate, or otherwise incur obligations to the City or waive any tax exemption under applicable law as a consequence of this Resolution, in that Fiscal Court retains all discretion under applicable law to enter Interlocal Agreements and other contractual arrangements with the City in the future, but is not required to do so by this Resolution;

WHEREAS, the Fiscal Court does not agree to any limitations on the zone classification or other land use permitting rights as to the Park as a result of this Resolution and such property remains subject to KRS 100.324(4) governing "public facilities" review (but not approval) as a result of the Fiscal Court's ownership of the Park;

WHEREAS, the Fiscal Court waives any further statutory notice and objections of any type concerning the requested annexation of the Park, but does expect the County Judge/Executive and Clerk of the Fiscal Court to timely receive signed and attested copies of any final annexation ordinance of the City as to the Park;

WHEREAS, the Fiscal Court expects the Bardstown Police and any other providers of City services to the Park to confer with Park management in advance of the contemplated annexation in order to coordinate a smooth transition;

FISCAL COURT ORDERS

JULY 19, 2022

BOOK 43

REGULAR SESSION OF NELSON FISCAL COURT

PAGE 651

WHEREAS, this Resolution is effective as of the date on which the signature of the County Judge/Executive is attested to by the Clerk of the Fiscal Court.

NOW THEREFORE, the Fiscal Court Resolves and Directs the Clerk of the Fiscal Court and County Judge/Executive as follows:

1. The Fiscal Court consents to the annexation of the Park by the City subject to the above Whereas clauses and directs the Clerk of the Fiscal Court and County Judge/Executive to take all necessary action to effect such consent.
2. The County Judge/Executive is authorized to execute any further correspondence or documents consistent with this Resolution and as reasonably necessary to effect the contemplated annexation of the Park; except that incurrence of any financial obligation exceeding \$500.00 for Nelson County or the Fiscal Court in connection with such annexation shall require Fiscal Court approval.
3. This Resolution shall be referenced in and attached to the Minutes of the Meeting of the Fiscal Court at which it is voted upon;
4. Upon this Resolution's passage, signature, and attestation, and approval and signature of Meeting Minutes for the Meeting at which this Resolution is passed, the Judge/Executive or the Clerk of the Fiscal Court shall promptly send a copy of such Resolution and Minutes to the Mayor of the City at City Hall and confirm receipt;



HON. DEAN WATTS
JUDGE/EXECUTIVE, NELSON COUNTY

ATTEST:

PRINT NAME: Jeanelle Hall Sidbottom
CLERK OF FISCAL COURT
DATE: 7/19/2022

FISCAL COURT ORDERS

JULY 19, 2022

BOOK 43

REGULAR SESSION OF NELSON FISCAL COURT

PAGE 652

Nelson County Fiscal Court RESOLUTION

WHEREAS, the Nelson County Fiscal Court agrees the following roads, on the attached Appendix A, are part of the county road system.

WHEREAS, the Nelson County Fiscal Court agrees the following roads, on the attached Appendix B, are not part of the county road system.

WHEREAS, the Nelson County Fiscal Court maintains these roads on Appendix A.

NOW THEREFORE, be it resolved that the Nelson County Fiscal Court agrees the listed roads on Appendix A are part of the county road system and those listed on Appendix B are not part of the county road system.

Done this 19 day of 7 2022. Motion by Bernard Fee, seconded by Eric Skolburne with 5 members present voting 5 in favor.

BY: 
County Judge Executive

ATTEST: 

ITS: _____

FISCAL COURT ORDERS

JULY 19, 2022

BOOK 43

REGULAR SESSION OF NELSON FISCAL COURT

PAGE 653

Nelson County Fiscal Court Appendix A

ROUTE	ROAD NAME	LENGTH (MI)
CR-1001	SPENCER MATTINGLY LN	0.786
CR-1003	DOUBLE SPRINGS RD	0.409
CR-1004	PINKSTON RD	0.445
CR-1005	HUNTS LN	0.144
CR-1006	MARKS LN	1.307
CR-1007	WIRE LN	2.017
CR-1008	HILTON LN	2.345
CR-1009	GARRISON LN	0.587
CR-1010	SANDY HILL CT	0.098
CR-1011	ARNOLD LN	0.482
CR-1012	WOODLAWN RD	5.819
CR-1013	THOMAS LN	1.722
CR-1014	BROWNS LN	0.903
CR-1015	SANDERS LN	0.578
CR-1016	OLD BROWNS LN	0.22
CR-1017	DUGAN LN	1.727
CR-1018	CAMP RD	0.428
CR-1019	CAMPGROUND CHURCH NORTH RD	0.63
CR-1020	CAMPGROUND CHURCH RD	0.657
CR-1021	CAMPGROUND RD	1.49
CR-1022	YATES-COONEY NECK RD	5.695
CR-1023	HAGAN RD	0.94
CR-1024	MURPHY LN	1.092
CR-1025	HOLT RIDGE RD	2.703
CR-1026	SWEENEY RIDGE RD	1.62
CR-1027A	VICKIE DR	0.112
CR-1027B	CHURCH ST (CHAPLIN)	0.276
CR-1027C	NELSON AVE	0.349
CR-1027D	BROADWAY	0.381
CR-1027E	RICHARD DR	0.165
CR-1028	LAWRENCEBURG LOOP	1.401
CR-1029	HAHN RIDGE RD	1.335
CR-1030	PRATHER RIDGE RD	1.802
CR-1031	LOVE RIDGE RD	2.459
CR-1032	TERRELL LN	0.313
CR-1033	FAIRMOUNT LOOP	0.224
CR-1034	HIGHVIEW CHURCH RD	2.623

FISCAL COURT ORDERS

JULY 19, 2022

BOOK 43

REGULAR SESSION OF NELSON FISCAL COURT

PAGE 654

CR-1035	GREEN CHAPEL RD	3.628
CR-1036	TIMBER CREEK RD	2.602
CR-1037	VAN BUREN RD	0.527
CR-1038	WALDRIDGE RD	0.975
CR-1039	OLD LOUISVILLE RD CONNECTOR	0.04
CR-1040	DRAKE RIDGE RD	0.303
CR-1041	CHOWNING LN	0.562
CR-1042	OCKERMAN LN	0.863
CR-1043	CORNISH LN	0.833
CR-1044	TIMBER CREEK LOOP	0.265
CR-1044-70	TIMBER CREEK LOOP CONN	0.024
CR-1046	COOKSEY LN	0.1
CR-1047	SIMPSON RD	0.63
CR-1048	AMERICAN DR	0.748
CR-1049	GOWIN LN	0.253
CR-1050	PETE HAHN RD	0.346
CR-1051	EGGEN RD	1.137
CR-1052	BIG SPRINGS RD	0.411
CR-1053	STEVENS LN	2.251
CR-1054	HERSHELL LEATHERS LN	0.252
CR-1055	PRATIER LN	0.085
CR-1056	SIMPSON CREEK RD	2.074
CR-1057	RUSSELL RD	1.124
CR-1058	WILKERSON RD	4.203
CR-1059	TURNER LN	0.084
CR-1060	FAIRFIELD CEMETERY LOOP	0.309
CR-1061	LAKESHORE DR	0.104
CR-1062	PLUM RUN RD	8.924
CR-1063	MURRAYS RUN RD	6.981
CR-1064	WOODLAWN SPGS	0.286
CR-1066	GRAYS RUN RD	0.27
CR-1067A	WELLS LN	0.071
CR-1067B	TICHENOR LN	0.109
CR-1067C	DUDLEY LN	0.108
CR-1067D	HUGHES HILL LN	0.057
CR-1068	TWIN OAKS DR	0.225
CR-1069	CHESTER HAHN RD	0.547
CR-1070	IRISH RIDGE RD	2.287
CR-1071	STONER RD	1.981
CR-1072	FAIRWAY III	0.126
CR-1073	LANDMARK DR	0.182
CR-1074	MAUD COOKSEY LN	0.639
CR-1075	BRITTANY DR	0.285

FISCAL COURT ORDERS

JULY 19, 2022

BOOK 43

REGULAR SESSION OF NELSON FISCAL COURT

PAGE 655

CR-1076	COUNTRYSIDE DR	0.141
CR-1077	NALL LN	0.207
CR-1078	FREEDOM PL	0.049
CR-1079	WOODLAWN CONN	0.096
CR-1081A	EASTLAND DR	0.332
CR-1081B	MCDONALD DR	0.235
CR-1081C	KEENELAND DR	0.282
CR-1081E	NALLY CT	0.062
CR-1081F	HOUCK DR	0.132
CR-1081F-70	HOUCK DR CONN	0.011
CR-1081G	HILL ST	0.558
CR-1081H	WASHINGTON AVE	0.134
CR-1081J	JEFFERSON AVE	0.349
CR-1081K	LINCOLN AVE	0.178
CR-1081L	GRANT AVE	0.121
CR-1081M	KENNEDY AVE	0.212
CR-1081N	PLANTATION CIR	0.048
CR-1082	EAGLE PASS	0.363
CR-1083	NAVAJO DR	0.418
CR-1084	ROYAL OAK DR	0.398
CR-1085	WOODSIDE DR	0.329
CR-1086	LIBERTY LN	0.132
CR-1087	REPUBLIC CT	0.039
CR-1088	LEIGH TER	0.476
CR-1089	ALLOWAY CT	0.076
CR-1091	DEEP SPRINGS DR	0.66
CR-1092	INDEPENDENCE AVE	0.252
CR-1093	UNION CIR	0.058
CR-1094	ASHLEIGH WAY	0.274
CR-1095	HAVERLY DR	0.137
CR-1096	ALLIE CT	0.053
CR-1097	THRUWAY DR	0.088
CR-1098	WHISPERING OAK DR	0.464
CR-1099	SEMINOLE CT	0.284
CR-1100	HUBBARDS LN	1.399
CR-1101	WATER PLANT LN	0.175
CR-1103	BRIARCLIFF RD	0.139
CR-1104	SUTHERLAND RD	1.65
CR-1105	MCINTYRE LN E	0.149
CR-1106	POTTERSHP RD	5.645
CR-1107	ED BRENT RD	0.509
CR-1109	LESLIE BALLARD LOOP	0.264
CR-1110	LESLIE BALLARD LN	0.997

FISCAL COURT ORDERS

JULY 19, 2022

BOOK 43

REGULAR SESSION OF NELSON FISCAL COURT

PAGE 656

CR-1111	CANE RUN LOOP	0.496
CR-1112	BATSELL DR	0.348
CR-1113	BOTLAND LOOP	0.507
CR-1114	AVERY LOOP	0.376
CR-1115	TRINITY CEMETERY LOOP	0.237
CR-1116	FREDERICKTOWN RD	0.342
CR-1117	HUDSON DR	0.457
CR-1118	MCINTYRE LN	0.669
CR-1119	BEAR CREEK WAY	0.845
CR-1120	SURGE LN	0.76
CR-1121	ED PILE RD	0.763
CR-1122	SUMMERS LN	1.707
CR-1123	TOM GREER RD	2.96
CR-1124	SHUMATE LN	0.969
CR-1125	GREER LN	2.144
CR-1126	BORDERS LN	2.398
CR-1127	HUTCHINS LN	1.305
CR-1128	POTTERSHP LOOP	0.353
CR-1129	GILKEY RUN RD	0.538
CR-1130	MARSHALL LN	0.417
CR-1131	JOE LYVERS RD	0.519
CR-1132	WIMPSETT SCHOOLHOUSE RD	0.865
CR-1133	TOM BALLARD RD	0.287
CR-1134	TERRAPIN LN	0.843
CR-1135	J R BALLARD LN	0.419
CR-1136	HALL SIMPSON RD	3.027
CR-1137	CLARKTOWN RD	3.276
CR-1138	FOGLE RD	1.897
CR-1139	T BRADLEY LN	0.65
CR-1140	JIM CLARK RD	4.181
CR-1141	LESLIE CLARK RD	0.851
CR-1142	LYTLE CECIL LN	0.399
CR-1143	ETHEL SMITH LN	0.293
CR-1144	CARDINAL HL	0.644
CR-1145A	SHIRLEY AVE	0.238
CR-1145B	CENTER ST	0.169
CR-1145C	CHURCH ST (NEW HOPE)	0.215
CR-1145D	BELL ST	0.058
CR-1145E	DEPOT ST	0.028
CR-1146	STRINGTOWN RD	1.216
CR-1147	COON HOLLOW RD	2.7
CR-1148	SULPHUR LICK RD	0.187
CR-1149	EDDIE MILES RD	2.424

FISCAL COURT ORDERS

JULY 19, 2022

BOOK 43

REGULAR SESSION OF NELSON FISCAL COURT

PAGE 657

CR-1150	ROBERT TAYLOR LN	0.838
CR-1151	BALLARD LN	1.101
CR-1152	RITCHIE LN	1.971
CR-1153	QUARRY LN	1.899
CR-1154	R L GREER LN	0.266
CR-1155	JUNIOR GOBEN LN	0.16
CR-1156	HURSTBORNE LN	0.379
CR-1157	PAPPY CECIL LN	0.504
CR-1158	QUARRY LN E	0.376
CR-1159	OLD SUTHERLAND PIKE	0.289
CR-1160	ST THOMAS LOOP	0.337
CR-1161	ST THOMAS CT	0.316
CR-1162	BARTLEY LN	0.17
CR-1163	ORA BRENT LN	0.329
CR-1164	POPLAR FLAT CEMETERY RD	0.436
CR-1165	ANTHONY GREENWELL LN	0.155
CR-1166	PASCIAL BALLARD LN	0.376
CR-1167	EDWIN CECIL LN	0.559
CR-1168	PERMAN CLARK LN	0.53
CR-1169	TOLLGATE RD	1.037
CR-1170	WILLOWSRING LN	0.06
CR-1171	COUNTY LINE RD	0.337
CR-1172	MASTERSON LN	0.298
CR-1173	MOSS BROWN RD	0.464
CR-1174	ED PILE CONN	0.081
CR-1175	BISHOP LN	0.231
CR-1176	MILL CREEK LN	0.209
CR-1177	IVY AVE	0.128
CR-1178	BALLTOWN CONN	0.202
CR-1179	FOXFIRE RD	0.636
CR-1180	BREFZY WAY	0.402
CR-1181	WINDRIFT CT	0.303
CR-1182	OAK KNOLL DR	0.658
CR-1183	WHITE OAK LN	0.076
CR-1184	BLACK OAK LN	0.037
CR-1185	RED OAK LN	0.116
CR-1186	FARMAWAY DR	0.803
CR-1187	MAYWOOD AVE	0.868
CR-1188	WAVERLY DR	0.188
CR-1189	CAMBRON DR	0.335
CR-1190	LAUREL DR	0.572
CR-1191	CLIFFWOOD DR	0.205
CR-1192	FARMINGTON DR	0.276

FISCAL COURT ORDERS

JULY 19, 2022

BOOK 43

REGULAR SESSION OF NELSON FISCAL COURT

PAGE 658

CR-1193	LOOKOUT CT	0.335
CR-1194	HARRY RUCKER RD	0.491
CR-1195	AUBERRY CT	0.039
CR-1197	N HOWARD ST	0.376
CR-1198	S HOWARD ST	0.139
CR-1199	PLAINVIEW DR	0.123
CR-1200	BROTHERS LN	0.672
CR-1201	BENNETTS LN	3.513
CR-1202	HUMPHREY LN	1.018
CR-1203	TOM VITTITOW LN	0.238
CR-1204	LEAMON FORD RD	1.998
CR-1205	GREENWELL FORD RD	1.878
CR-1206	SIMON GREENWELL LN	0.983
CR-1207	ICE RD	0.834
CR-1208	ICETOWN RD	4.381
CR-1209	CULVER LN	0.912
CR-1210	QUARRY LOOP	0.819
CR-1211	PRICE CREEK LOOP	0.277
CR-1212	NEW VITTITOW LN	0.583
CR-1213	PRICE CREEK LN	0.296
CR-1214	HALISY WOOD LOOP	0.514
CR-1215	HIGDON LOOP	0.473
CR-1216	THORNSBURY LN	0.121
CR-1218	NEWTON VALLEY LN	0.407
CR-1219	DEE HEAD RD	1.526
CR-1220	WALTER HALL RD	3.581
CR-1221	LEONARD HALL RD	1.949
CR-1222	CECIL RIDGE RD	2.1
CR-1223	STILES RD	0.076
CR-1224	FLATS RD	2.719
CR-1225	PERKINS LN	1.06
CR-1226	GADDYS FORD RD	1.365
CR-1227	GINSENG RD	1.071
CR-1228	BOONE MILL RD	0.947
CR-1229	BLANTON FORD RD	1.153
CR-1230	BIG LICK HOLLOW RD	0.872
CR-1231	SAWMILL RD	0.613
CR-1232	LEO CRUME LN	0.478
CR-1233	ALBERT WILLETT RD	0.166
CR-1234	PATTON RD	4.124
CR-1235	ROLLING FORK CHURCH RD	1.238
CR-1236	CULVERTOWN SCHOOLHOUSE RD	0.171
CR-1237	VITTITOW FORD RD	0.757

FISCAL COURT ORDERS

JULY 19, 2022

BOOK 43

REGULAR SESSION OF NELSON FISCAL COURT

PAGE 659

CR-1238	NELSONVILLE LN	0.191
CR-1239	SOUTH STILLWELL RD	1.418
CR-1240	THORNSBURY LOOP	0.152
CR-1241	SHADY LN	2.869
CR-1242A	POST OFFICE CT	0.141
CR-1242B	BUTTERMILK ST	0.062
CR-1242C	HIGHLAND AVE	0.33
CR-1242D	EDWARDS AVE	0.311
CR-1242E	EDWARDS LN	0.113
CR-1243	OLD NELSONVILLE RD	1.05
CR-1244	PETERSBURG RD	4.29
CR-1245	GONZA CLARK LN	0.424
CR-1246	SALT SPRING LOOP	0.322
CR-1247	SPALDING HOLLOW RD	0.869
CR-1248	KEITH KNOB RD	1.94
CR-1249	MT MORIAH RD	1.126
CR-1250	LICK CREEK RD	1.044
CR-1251	ALLEN RD	0.875
CR-1252	BOTTO LN	0.312
CR-1253	WATERTOWER LOOP	0.137
CR-1254	TIMBER TRAILS RD	0.343
CR-1255	JOE NALLEY RD	0.406
CR-1256	NORTH STILLWELL RD	2.25
CR-1257	PORTER LN	0.315
CR-1258	F M HEAD LN	0.133
CR-1259	HOWARDSTOWN CONN	0.111
CR-1260	PERKINS LOOP	0.121
CR-1261	HUMPHREY RD E	0.147
CR-1262	DONES LN	0.421
CR-1263	SPALDING HOLLOW RD NE	0.136
CR-1264	HOWARDSTOWN BOAT RAMP	0.129
CR-1265	BOWLING PIKE	0.308
CR-1266	NELSONVILLE LOOP	0.893
CR-1267	CLEAR CREEK DR	1.351
CR-1268	TEN OAKS DR	0.087
CR-1269	HIGH PINE CT	0.209
CR-1271	HAVEN RIDGE DR	0.311
CR-1272	HAVEN WOOD CT	0.097
CR-1273	HAVEN OAK CT	0.048
CR-1274	OLD LOUISVILLE RD	2.347
CR-1275	OLD LOUISVILLE CT	0.265
CR-1276	DELAWARE CT	0.182
CR-1277	BAY CT	0.038

FISCAL COURT ORDERS

JULY 19, 2022

BOOK 43

REGULAR SESSION OF NELSON FISCAL COURT

PAGE 660

CR-1278	SADDLEBROOK DR	0.471
CR-1279	WHIRLAWAY CT	0.093
CR-1280	CAVALCADE CIR	0.107
CR-1281	ARISTIDES CT	0.078
CR-1282	UNBRIDLED CIR	0.057
CR-1283	PEMBROOKE DR	0.456
CR-1284	BROOKVIEW LN	0.086
CR-1285	STREAMVIEW LN W	0.018
CR-1286	STREAMVIEW LN E	0.037
CR-1287	POPLAR WOOD DR	0.462
CR-1288	CHAMPIONSHIP DR	0.118
CR-1289	CLAYTON PARK DR	0.196
CR-1290	CAMELLIA AVE	0.189
CR-1291	MAGNOLIA DR	0.083
CR-1293	GRIGSBY LN	0.581
CR-1294	MALLARDS CV	0.231
CR-1295	PRESLEY DR	0.172
CR-1296	MINORS LN	0.135
CR-1297	SOUTHFORK TRL	0.242
CR-1298	COLONEL COX RD SOUTH	0.199
CR-1299	LOUISVILLE FARMS RD	1.611
CR-1299-70	LOUISVILLE FARMS CONNECTOR	0.071
CR-1300	COPPERFIELD WAY	0.45
CR-1301A	CLERMONT DR	0.203
CR-1301B	NORTH DR	0.146
CR-1301C	STUMPI CT	0.317
CR-1301E	CESSNA DR	0.102
CR-1301F	LYDIAN LOOP	0.195
CR-1301G	BO BEAN WAY	0.145
CR-1301H	PIPER DR	0.199
CR-1301N	STINSON DR	0.348
CR-1302	CANEY FORK RD	1.061
CR-1303	VIRGINIA AVE	0.765
CR-1304	MARY JO BLVD	0.839
CR-1305	SUNSHINE DR	0.307
CR-1307	HOBBS LN	2.456
CR-1308	SPALDING LN	0.368
CR-1309	SULLIVAN LN	2.439
CR-1310	HIBBS LN	3.071
CR-1312	LYDDANE LN	0.704
CR-1313	WHITESIDES RD	3.541
CR-1314	KING RD	1.424
CR-1315	HALEAH DR	0.41

FISCAL COURT ORDERS

JULY 19, 2022

BOOK 43

REGULAR SESSION OF NELSON FISCAL COURT

PAGE 661

CR-1316	ALI ENDER LN	0.369
CR-1317	COOK RD	0.234
CR-1318	CRENSHAW LN	0.115
CR-1319	AZALEA AVE	0.211
CR-1320	HIGH GROVE LN	0.091
CR-1321	WHEELER-WRIGHT LN	0.668
CR-1322	BERMAN WELLS RD	0.561
CR-1323	LASLEY RUN RD	0.471
CR-1324	THOMPSON HILL RD	1.213
CR-1325	BACK RUN RD	0.227
CR-1326	OLDE TOWNE DR	0.285
CR-1327	MOBLEY MILL RD	4.17
CR-1328	SOUTH ST GREGORY CHURCH RD	0.904
CR-1329	CANEY FOX RD	0.796
CR-1330	T HAHN RD	1.467
CR-1331	LUTES LN	0.909
CR-1332	CEDAR GROVE RD	1.599
CR-1333	WILSON CREEK RD	0.866
CR-1334A	DEATSVILLE CONN	0.155
CR-1334B	BARE ST	0.195
CR-1334C	JESSIE JAMES RD	0.13
CR-1334D	OLD HENPECK RD	0.467
CR-1334E	MARR LN	0.062
CR-1334F	DOWNNS LN	0.16
CR-1335	ANTLERS TRACE DR	0.57
CR-1336	HALL LOOP	0.287
CR-1337	TOM WALKER LN	0.118
CR-1338	SAMUELS CHURCH RD	0.456
CR-1339	PEAVLER LN	0.519
CR-1340	HARRISON FORK RD	4.705
CR-1341	THOMPSON-DONES LN	0.799
CR-1342	MASDEN RD	1.516
CR-1343	ROSSLAND DR	0.318
CR-1344	TREE TOP DR	0.296
CR-1345	NAZARETH DR	0.766
CR-1346	HARDIN LESLIE RD	1.482
CR-1347	TEWELL CREEK RD	0.637
CR-1348	MCCUBBINS LN	1.19
CR-1349	HUGH ICE LOOP	0.821
CR-1350	TULIP DR	0.301
CR-1351	AIRPORT RD	0.937
CR-1352	BARNES RD	2.05
CR-1353	WHEELER RD	1.816

FISCAL COURT ORDERS

JULY 19, 2022

BOOK 43

REGULAR SESSION OF NELSON FISCAL COURT

PAGE 662

CR-1354	LUTHERAN CHURCH RD	1.777
CR-1355	STONEHOUSE RD	1.728
CR-1356A	GREEN MEADOW CT	0.077
CR-1356B	MEADOW LN	0.34
CR-1356C	RAISOR AVE	0.405
CR-1356D	OLD STONEHOUSE RD	0.15
CR-1356E	NITA DR	0.076
CR-1356F	WHITNEY DR	0.297
CR-1356G	BARBARA LN	0.09
CR-1356H	HUNTERS LN W	0.371
CR-1356J	DIXIE LN	0.234
CR-1356K	LYNN CT	0.155
CR-1356L	DONNA LN	0.189
CR-1356M	DONNA WAY	0.173
CR-1356N	STERLING CT	0.084
CR-1356O	CHERRYWOOD DR	0.203
CR-1356P	CREEL LN	0.296
CR-1356R	MEADOW RIDGE DR	0.217
CR-1356S	FROMAN CREEK CT	0.071
CR-1357	LINDEN AVE	0.065
CR-1358	FROMAN GREENWELL LN	1.003
CR-1359	BENELLI DR	0.463
CR-1361	BRANCH CT	0.171
CR-1362	SHANNON DR	0.323
CR-1363	STONEHOUSE RIDGE RD	1.062
CR-1365	STONEHOUSE TRI.	0.703
CR-1366	WESTLAND DR	0.185
CR-1367	WESTRIDGE CT	0.264
CR-1368	COUNTRY SQUIRE LN	0.62
CR-1369	LUDWICK DR	0.222
CR-1370	MEADOW DR	0.224
CR-1371	WELLER LOOP	0.668
CR-1372	DEATSVILLE LOOP	0.83
CR-1373	ROBIN HOOD DR	0.175
CR-1374	MILLER CALL LN	0.222
CR-1376	HUNTERS LN	0.786
CR-1377	HIGHLAND DR	0.422
CR-1378	MANN DR	0.229
CR-1379	WILLOW CT	0.279
CR-1380	WITHROW CREEK RD	0.68
CR-1381	BUFFALO HILL RD	0.133
CR-1382	NORTH ST GREGORY CHURCH RD	1.207
CR-1383	RIVERBROOKE DR	0.591

FISCAL COURT ORDERS

JULY 19, 2022

BOOK 43

REGULAR SESSION OF NELSON FISCAL COURT

PAGE 663

CR-1384	VENETIAN WAY	0.593
CR-1384-80	VENETIAN WAY SPUR	0.049
CR-1384-81	VENETIAN WAY SPUR	0.035
CR-1385	FRANCES DR	0.349
CR-1386	WEDGEWOOD DR	0.435
CR-1387	METALWOOD DR	0.251
CR-1388	STEEPLECHASE CT	0.096
CR-1389	TIMBERWOOD CT	0.061
CR-1390	BUCKEYE DR	0.15
CR-1391	ABBAY RDG	1.009
CR-1392	COVENTRY LN	0.212
CR-1393	DONOVAN HTS	0.12
CR-1394	PECAN DR	0.15
CR-1395	SOUTH CHARITY LN	0.404
CR-1396	HERITAGE DR	0.371
CR-1397	REGENCY CT	0.085
CR-1398	ALDER DR	0.341
CR-1399	REDWOOD DR	0.563
CR-1400	WELCH LN	0.253
CR-1403	PREAKNESS DR	0.44
CR-1404	EAST MILESTONE CT	0.198
CR-1405	EAST SANDSTONE CT	0.076
CR-1406	BUCK RUN TRL	0.284
CR-1407	WEST MILESTONE CT	0.185
CR-1408	WEST SANDSTONE CT	0.16
CR-1409	WILSON CREEK SPUR RD	0.164
CR-1411	CHAPEL HILL CT	0.192
CR-1412	STONEFIELD WAY	0.33
CR-1413	COBBLESTONE CT	0.122
CR-1414	BLAKENROD BLVD	0.638
CR-1415A	TOPEKA LN	0.279
CR-1415B	LOMBARD CIR	0.086
CR-1415C	FRANKFORT CT	0.046
CR-1415D	LEXINGTON CT	0.063
CR-1415E	CHESAPEAKE TRL	0.561
CR-1415F	PEABODY LOOP	0.932
CR-1415G	PACIFIC CT	0.034
CR-1415H	ILLINOIS WAY	0.249
CR-1415J	OHIO CT	0.113
CR-1415K	IRVINE CT	0.037
CR-1415L	JELLICO DR	0.311
CR-1415M	LANCASTER LN	0.153
CR-1415N	RICHMOND CT	0.049

FISCAL COURT ORDERS

JULY 19, 2022

BOOK 43

REGULAR SESSION OF NELSON FISCAL COURT

PAGE 664

CR-1415P	CHATTANOOGA DR	0.288
CR-1415Q	NASHVILLE DR	0.14
CR-1415R	VERSAILLES CT	0.079
CR-1415S	PENNYRILE DR	0.189
CR-1415T	SANTA FE CT	0.096
CR-1415U	SHORT LINE DR	0.139
CR-1415V	ROCKTON CT	0.116
CR-1415W	MONTEGA LN	0.3
CR-1415X	SILVER LAKE CT	0.071
CR-1415Y	CORMANS CROSSING BLVD	0.12
CR-1415Z	BRANSON CIR	0.051
CR-1416	DAY HILL CT	0.15
CR-1417	LEGACY WAY	0.124
CR-1418	GALLERY CIR	0.069
CR-1419	WETHERBY AVE	0.334
CR-1420	BERETTA CT	0.266
CR-1422	THOMAS NELSON DR	0.109
CR-1425	ENTERPRISE WAY	0.119
CR-1426	ELIJAH WAY	0.099
CR-1427	VAUGHN RD	0.1
CR-1428	ETHEN ALAN DR	0.234
CR-1429	ICETOWN CONNECTOR	0.144
CR-1431	VALLEY SPG	0.08
CR-1432	FOREST SPRINGS DR	0.157
CR-1433	FOREST VIEW CT	0.118
CR-1434	FOUR SEASONS DR	0.32
CR-1467	MAIN AVE	0.137
CR-1469	VILLAGE DR	0.133
CR-1470	WEST DR	0.11
CR-1472	ASHFORD LN	0.375
CR-1473	SPRINGHURST DR	0.349
CR-1474	SAMUELS LOOP	0.133
CR-1475	SHERMAN OAKS DR	0.23
CR-1476	CREEKSIDE DR	0.433
CR-1477	CROSSCREEK CT	0.223
CR-1478	CREEK POINTE DR	0.309
CR-1479	SPRING CT	0.151
CR-1480	WALNUT CREEK DR	0.405
CR-1481	IRON CREEK CIR	0.146
CR-1482	SIMMENTAL CREEK RDG	0.145
CR-1483	HOLLY CREEK CT	0.148
CR-1484	COXS CREEK LN N	0.107
CR-1485	COXS CREEK LN S	0.056

FISCAL COURT ORDERS

JULY 19, 2022

BOOK 43

REGULAR SESSION OF NELSON FISCAL COURT

PAGE 665

CR-1486	NORTH CHARITY LN	0.249
CR-1487	LOCUST GROVE CT	0.37
CR-1487-80	LOCUST GROVE CT SPUR	0.017
CR-1490	MEADOWBROOK LN	0.302
CR-1500	WOODHILL RD	0.609
CR-1504	COLVIN CT	0.121
CR-1512	CRYSTAL SPRINGS DR	0.165
CR-1513	GLENVIEW DR	0.539
CR-1514	DEMOCRATIC WAY	0.141
CR-1515	QUIET SPRING DR	0.148
CR-1516	THUNDER SPRING DR	0.147
CR-1517	CLEAR SPRING DR	0.143
CR-1518	FOX RIDGE RD	0.166
CR-1519	ROLLING HILLS DR	0.07
CR-1521	ANDREA CT	0.285
CR-1525	BALLARD SPRINGS CT	0.186
CR-1526	EMORY CT	0.06
CR-1527A	FREEMAN AVE	0.321
CR-1527B	ADISON AVE	0.132
CR-1527C	GARDEN DR	0.199
CR-1527D	COUNCIL DR	0.214
CR-1600	ST THOMAS LN	0.817
CR-1601	PINEHURST DR	0.319
CR-1602	MACY CT	0.046
CR-1603	JESSICA DR	0.347
CR-1604	BRYAN DR	0.275
CR-1606	MARIE DR	0.186
CR-1607	ASITON CT	0.076
CR-1608	BRENTWOOD LN	0.372
CR-1609	BETHANY CT	0.143
CR-1610	REMINGTON DR	0.716
CR-1611	W T THOMPSON LN	0.397
CR-1612	MANOR AVE	0.2
CR-1615	GLENWOOD DR	0.115
CR-1616	RUBY CT	0.088
CR-1617	EMERALD CT	0.117
CR-1618	SAPPHIRE CT	0.427
CR-1619	JIM CLARK LOOP	0.223
CR-1620	HUTCHINS CT	0.729
CR-1620-80	HUTCHINS CT SPUR	0.105
CR-1621	HUTCHINS RIDGE RD	0.441
CR-1622	POLLEY DR	0.259
CR-1623	DEER VALLEY CT	0.129

FISCAL COURT ORDERS

JULY 19, 2022

BOOK 43

REGULAR SESSION OF NELSON FISCAL COURT

PAGE 666

CR-1626	MORGAN CT	0.062
CR-1627	EMERSON CT	0.061
CR-1628	RYAN CT	0.11
CR-1629	SUNFISH CREEK DR	0.175
CR-1630	MAGGIE LN	0.223
CR-1631	CASTLE DR	0.227
CR-1632	MILLWOOD WAY	0.405
CR-1632A	GRIST MILL CT	0.064
CR-1632B	ELIZABETH WAY	0.07
CR-1632C	SANDS CT	0.067
CR-1632D	GABRIEL WAY	0.067
CR-1632E	FUTURE ST	0.04
CR-1700	OLD BOSTON RD	0.513

FISCAL COURT ORDERS

JULY 19, 2022

BOOK 43

REGULAR SESSION OF NELSON FISCAL COURT

PAGE 667

Nelson County Fiscal Court Appendix B

ROUTE	ROAD NAME	LENGTH (MI)
CR-1270	TWIN ISLAND LN	0.774
CR-1375	GEORGE MEYER LN	0.647
CR-1605	HITE LN	0.346

FISCAL COURT ORDERS

JULY 19, 2022

BOOK 43

REGULAR SESSION OF NELSON FISCAL COURT

PAGE 668

2013 International Dump Truck



Cracked Engine Sleeve



Damaged Head and Valve



FISCAL COURT ORDERS

JULY 19, 2022

BOOK 43

REGULAR SESSION OF NELSON FISCAL COURT

PAGE 669

RESOLUTION

Fiscal Court of NELSON County

Resolution adopting and approving the execution of a Rural Secondary Program Agreement between the Fiscal Court and the Commonwealth of Kentucky, Transportation Cabinet, Department of Rural and Municipal Aid, and accepting all roads and streets referred to therein as being a part of the County Road System.

Be it resolved by the Fiscal Court that:

The Fiscal Court does hereby certify that all roads and streets referred to in said Agreement are county roads as defined in KRS 178.010 (1) (b); and

The Fiscal Court does hereby ratify and adopt all statements, representations, warranties, covenants, and agreements contained in said Agreement and does hereby accept said Agreement and by such acceptance agrees to all the terms and conditions therein stated; and

The County Judge/Executive of the county is hereby authorized and directed to sign said Agreement as set forth on behalf of the Fiscal Court of NELSON County, and the County Clerk of NELSON County is hereby authorized and directed to certify thereto.

FISCAL COURT ORDERS

JULY 19, 2022

BOOK 43

REGULAR SESSION OF NELSON FISCAL COURT

PAGE 671

NELSON COUNTY
BRIDGE PROJECT
ON HILTON ROAD (CR 1008)
\$80,000 – CB01 BRIDGE FUNDS

AGREEMENT BETWEEN
COMMONWEALTH OF KENTUCKY
TRANSPORTATION CABINET
DEPARTMENT OF RURAL AND MUNICIPAL AID
AND
NELSON COUNTY

THIS AGREEMENT, entered into by and between the Commonwealth of Kentucky, Transportation Cabinet, Department of Rural and Municipal Aid, hereinafter referred to as the "Department" and the NELSON COUNTY Fiscal Court, hereinafter referred to as the "County."

WITNESSETH:

WHEREAS, it would be to the benefit of the traveling public to replace a bridge on Hilton Road (CR 1008), which shall hereinafter be referred to as the "Project"; and

WHEREAS, the County has expressed its desire to perform the work for the aforementioned Project and to be responsible for all phases of the Project;

NOW THEREFORE, in consideration of these premises and the mutual covenants contained herein, the parties agree as follows:

1. The Department shall be responsible for providing and agrees to reimburse up to the amount of eighty percent (80%) of the actual Rural Secondary project cost but in no case to exceed \$80,000 for the abovementioned Project. In no event shall the County not be responsible for twenty percent (20%) of the cost.
2. If the Project is performed by Contract, the County shall employ only contractors prequalified by the Kentucky Transportation Cabinet for the work items included in the Project and shall comply with all legal bidding requirements including, but not limited to, the provisions of KRS 45A and 424. Concurrence must be obtained by the County through the District 4 Chief District Engineer in Elizabethtown, KY, prior to the awarding of any contract for work or materials to be used on this Project. This

FISCAL COURT ORDERS

JULY 19, 2022

BOOK 43

REGULAR SESSION OF NELSON FISCAL COURT

PAGE 672

NELSON COUNTY
BRIDGE PROJECT
ON HILTON ROAD (CR 1000)
\$80,000 – CB01 BRIDGE FUNDS

requirement shall not be limited to, but shall specifically apply to, all 20-foot bridges and above, defined as inventoried structures.

3. The County shall cause the Project to be constructed to a level which meets applicable county road and bridge standards (all bridges will be required to meet or exceed an H-20 loading); *approval from Bridge Preservation Branch of Division of Maintenance MUST BE OBTAINED before ANY additional load is added to any inventoried structure.* Furthermore, all materials paid for by the Department used on, or incorporated into, the Project shall meet the requirements specified in the Highway Department's Specifications for Road and Bridge Construction, current edition of State Specifications guidelines. The County will obtain any required permits or approval of plans for work to be accomplished on state-owned right-of-way from the Cabinet's District 4 Office in Elizabethtown, KY. These requirements shall not be limited to, but shall specifically apply to, all 20-foot and above, bridges, defined as inventoried structures.
4. *If the proposed structure is inventoried (20 feet or longer) the designer shall be required to load rate all three (3) sided structures in accordance with the current edition of the Manual for Bridge Evaluation (MBE), AASHTO, Load and Resistance Factor Rating method (LRFR), current edition, and the Bridge Maintenance Procedures Manual. A list of the required rating trucks must be obtained from the Division of Maintenance/Bridge Maintenance Branch. Ratings shall be performed on all required trucks and must be included in the design calculations. All costs to perform these ratings are incidental to the three (3) sided structure. Load Rating for County Route reference sheets are attached and will be used when pertaining to culverts prior to opening to the public.*
5. To the extent permitted by law, the County shall indemnify and hold harmless the Department and all of its officers, agents, and employees from all suits, actions, or claims of any character because of any injuries or damages received by any person, persons, or property resulting from construction of the Project.
6. The County agrees to be responsible for all cost associated with this project over and above eighty percent (80%) of the actual Project cost. The County further agrees to be responsible for all of the costs over and

FISCAL COURT ORDERS

JULY 19, 2022

BOOK 43

REGULAR SESSION OF NELSON FISCAL COURT

PAGE 673

NELSON COUNTY
BRIDGE PROJECT
ON HILTON ROAD (CR 1008)
\$80,000 – CB01 BRIDGE FUNDS

above \$80,000.

7. The effective date of this Agreement is the date of signature by the Secretary of the Transportation Cabinet. The Term of Eligible Reimbursement under this Agreement shall be three (3) years from the date of its execution unless extended or amended by written Agreement in accordance with the provisions of KRS 45A. Any and all funding obligated for any phase of this Project shall be available to reimburse the County for eligible work activities completed and costs incurred prior to expiration.
8. The County shall maintain for a period of three (3) years after the Rural Secondary Office within the Department issues a project close date, all records of material, equipment, and labor costs involved in the performance of the work for the Project. These records may be subject to audit by the Transportation Cabinet. In order to obtain reimbursement from the Department for the Project, the County shall submit to the Office of Rural and Secondary Roads documented invoices of materials, equipment, and labor used on the Project, including certification that the work was accomplished on a publicly maintained facility in accordance with this agreement.
9. The County may submit current billing reflecting the actual cost of the project during any given work period. This bill should indicate if it is for partial payment or final payment. The current billings will be paid within a reasonable time after receipt of same by the Department; however, in no event is the County to submit billings for work performed for less than a thirty-day (30) period.
10. The Department reserves the right to inspect the methods used in order to perform the work necessary to successfully complete the Project and also reserves the right to cease all work commenced under the terms of this agreement at any time.
11. The County will pass the attached Resolution and a copy of that resolution shall be attached to and made a part of this Agreement.

FISCAL COURT ORDERS

JULY 19, 2022

BOOK 43

REGULAR SESSION OF NELSON FISCAL COURT

PAGE 674

NELSON COUNTY
BRIDGE PROJECT
ON HILTON ROAD (CR 1008)
\$80,000 – CB01 BRIDGE FUNDS

MOA/PSC Exception Standard Terms and Conditions Revised December 2019

Whereas, the first party, the state agency, has concluded that either state personnel are not available to perform said function, or it would not be feasible to utilize state personnel to perform said function; and

Whereas, the second party, the Contractor, is available and qualified to perform such function; and

Whereas, for the abovementioned reasons, the state agency desires to avail itself of the services of the second party;

NOW THEREFORE, the following terms and conditions are applicable to this contract:

1.00 Effective Date:

This contract is not effective until the Secretary of the Finance and Administration Cabinet or his authorized designee has approved the contract and until the contract has been submitted to the Legislative Research Commission, Government Contract Review Committee ("LRC"). However, in accordance with KRS 45A.700, contracts in aggregate amounts of \$10,000 or less are exempt from review by the committee and need only be filed with the committee within 30 days of their effective date for informational purposes.

KRS 45A.695(7) provides that payments on personal service contracts and memoranda of agreement shall not be authorized for services rendered after government contract review committee disapproval, unless the decision of the committee is overridden by the Secretary of the Finance and Administration Cabinet or agency head, if the agency has been granted delegation authority by the Secretary.

2.00 LRC Policies:

This section does not apply to governmental or quasi-governmental entities.

Pursuant to KRS 45A.725, LRC has established policies which govern rates payable for certain professional services. These are located on the LRC webpage <https://apps.legislature.ky.gov/moreinfo/Contracts/homepage.html> and would impact any contract established under KRS 45A.690 et seq., where applicable.

3.00 Choice of Law and Forum:

This section does not apply to governmental or quasi-governmental entities.

This contract shall be governed by and construed in accordance with the laws of the Commonwealth of Kentucky. Any action brought against the Commonwealth on the contract, including but not limited to

FISCAL COURT ORDERS

JULY 19, 2022

BOOK 43

REGULAR SESSION OF NELSON FISCAL COURT

PAGE 675

NELSON COUNTY
BRIDGE PROJECT
ON HILTON ROAD (CR 1808)
\$80,000 – CB01 BRIDGE FUNDS

actions either for breach of contract or for enforcement of the contract, shall be brought in Franklin Circuit Court, Franklin County, Kentucky in accordance with KRS 45A.245.

4.00 EEO Requirements

The Equal Employment Opportunity Act of 1978 applies to All State government projects with an estimated value exceeding \$500,000. The contractor shall comply with all terms and conditions of the Act.

5.00 Cancellation:

Both parties shall have the right to terminate and cancel this contract at any time not to exceed thirty (30) days' written notice served on the other party by registered or certified mail.

6.00 Funding Out Provision:

The state agency may terminate this contract if funds are not appropriated to the contracting agency or are not otherwise available for the purpose of making payments without incurring any obligation for payment after the date of termination, regardless of the terms of the contract. The state agency shall provide the Contractor thirty (30) calendar days' written notice of termination of the contract due to lack of available funding.

7.00 Reduction in Contract Worker Hours:

The Kentucky General Assembly may allow for a reduction in contract worker hours in conjunction with a budget balancing measure for some professional and non-professional service contracts. If under such authority the agency is required by Executive Order or otherwise to reduce contract hours, the agreement will be reduced by the amount specified in that document. If the contract funding is reduced, then the scope of work related to the contract may also be reduced commensurate with the reduction in funding. This reduction of the scope shall be agreeable to both parties and shall not be considered a breach of contract.

8.00 Authorized to do Business in Kentucky:

This section does not apply to governmental or quasi-governmental entities.

The Contractor affirms that it is properly authorized under the laws of the Commonwealth of Kentucky to conduct business in this state and will remain in good standing to do business in the Commonwealth of Kentucky for the duration of any contract awarded.

The Contractor shall maintain certification of authority to conduct business in the Commonwealth of Kentucky during the term of this contract. Such registration is obtained from the Secretary of State, who will also provide the certification thereof.

FISCAL COURT ORDERS

JULY 19, 2022

BOOK 43

REGULAR SESSION OF NELSON FISCAL COURT

PAGE 676

NELSON COUNTY
BRIDGE PROJECT
ON HILTON ROAD (CR 1000)
\$80,000 – CB01 BRIDGE FUNDS

Registration with the Secretary of State by a Foreign Entity:

Pursuant to KRS 45A.480(1)(b), an agency, department, office, or political subdivision of the Commonwealth of Kentucky shall not award a state contract to a person that is a foreign entity required by KRS 14A.9-010 to obtain a certificate of authority to transact business in the Commonwealth ("certificate") from the Secretary of State under KRS 14A.9-030 unless the person produces the certificate within fourteen (14) days of the bid or proposal opening. Therefore, foreign entities should submit a copy of their certificate with their solicitation response. If the foreign entity is not required to obtain a certificate as provided in KRS 14A.9-010, the foreign entity should identify the applicable exception in its solicitation response. Foreign entity is defined within KRS 14A.1-070.

For all foreign entities required to obtain a certificate of authority to transact business in the Commonwealth, if a copy of the certificate is not received by the contracting agency within the time frame identified above, the foreign entity's solicitation response shall be deemed non-responsive or the awarded contract shall be cancelled.

Businesses can register with the Secretary of State at <https://onestop.ky.gov/Pages/default.aspx>

9.00 Invoices for fees:

This section does not apply to governmental or quasi-governmental entities.

The Contractor shall maintain supporting documents to substantiate invoices and shall furnish same if required by state government.

10.00 Travel expenses, if authorized:

This section does not apply to governmental or quasi-governmental entities.

The Contractor shall be paid for no travel expenses unless and except as specifically authorized by the specifications of this contract or authorized in advance and in writing by the Commonwealth. The Contractor shall maintain supporting documents that substantiate every claim for expenses and shall furnish same if requested by the Commonwealth.

11.00 Other expenses, if authorized herein:

This section does not apply to governmental or quasi-governmental entities.

The Contractor shall be reimbursed for no other expenses of any kind, unless and except as specifically authorized within the specifications of this contract or authorized in advance and in writing by the Commonwealth.

FISCAL COURT ORDERS

JULY 19, 2022

BOOK 43

REGULAR SESSION OF NELSON FISCAL COURT

PAGE 677

NELSON COUNTY
BRIDGE PROJECT
ON HILTON ROAD (CR 1088)
\$80,000 – CB01 BRIDGE FUNDS

If the reimbursement of such expenses is authorized, the reimbursement shall be only on an out-of-pocket basis. Request for payment of same shall be processed upon receipt from the Contractor of valid, itemized statements submitted periodically for payment at the time any fees are due. The Contractor shall maintain supporting documents that substantiate every claim for expenses and shall furnish same if requested by the Commonwealth.

12.00 Purchasing and specifications:

This section does not apply to governmental or quasi-governmental entities.

The Contractor certifies that he/she will not attempt in any manner to influence any specifications to be restrictive in any way or respect nor will he/she attempt in any way to influence any purchasing of services, commodities or equipment by the Commonwealth of Kentucky. For the purpose of this paragraph and the following paragraph that pertains to conflict-of interest laws and principles, "he/she" is construed to mean "they" if more than one person is involved and if a firm, partnership, corporation, or other organization is involved, then "he/she" is construed to mean any person with an interest therein.

13.00 Conflict-of-interest laws and principles:

This section does not apply to governmental or quasi-governmental entities.

The Contractor certifies that he/she is legally entitled to enter into this contract with the Commonwealth of Kentucky, and by holding and performing this contract, he/she will not be violating either any conflict of interest statute (KRS 45A.330-45A.340, 45A.990, 164.390), or KRS 11A.040 of the executive branch code of ethics, relating to the employment of former public servants.

14.00 Campaign finance:

This section does not apply to governmental or quasi-governmental entities.

The Contractor certifies that neither he/she nor any member of his/her immediate family having an interest of 10% or more in any business entity involved in the performance of this contract, has contributed more than the amount specified in KRS 121.056(2), to the campaign of the gubernatorial candidate elected at the election last preceding the date of this contract. The Contractor further swears under the penalty of perjury, as provided by KRS 523.020, that neither he/she nor the company which he/she represents, has knowingly violated any provisions of the campaign finance laws of the Commonwealth, and that the award of a contract to him/her or the company which he/she represents will not violate any provisions of the campaign finance laws of the Commonwealth.

FISCAL COURT ORDERS

JULY 19, 2022

BOOK 43

REGULAR SESSION OF NELSON FISCAL COURT

PAGE 678

NELSON COUNTY
BRIDGE PROJECT
ON HILTON ROAD (CR 1008)
\$80,000 - CB01 BRIDGE FUNDS

15.00 Access to Records:

The state agency certifies that it is in compliance with the provisions of KRS 45A.695, "Access to contractor's books, documents, papers, records, or other evidence directly pertinent to the contract." The Contractor, as defined in KRS 45A.030, agrees that the contracting agency, the Finance and Administration Cabinet, the Auditor of Public Accounts, and the Legislative Research Commission, or their duly authorized representatives, shall have access to any books, documents, papers, records, or other evidence, which are directly pertinent to this agreement for the purpose of financial audit or program review. The Contractor also recognizes that any books, documents, papers, records, or other evidence, received during a financial audit or program review shall be subject to the Kentucky Open Records Act, KRS 61.870 to 61.884. Records and other prequalification information confidentially disclosed as part of the bid process shall not be deemed as directly pertinent to the agreement and shall be exempt from disclosure as provided in KRS 61.878(1)(c).

16.00 Social security: (check one)

This section does not apply to governmental or quasi-governmental entities.

_____ The parties are cognizant that the state is not liable for social security contributions, pursuant to 42 U.S. Code, section 418, relative to the compensation of the second party for this contract.

_____ The parties are cognizant that the state is liable for social security contributions, pursuant to 42 U.S. Code, section 418, relative to the compensation of the second party for this contract.

17.00 Violation of tax and employment laws:

KRS 45A.485 requires the Contractor and all subcontractors performing work under the contract to reveal to the Commonwealth, prior to the award of a contract, any final determination of a violation by the Contractor within the previous five (5) year period of the provisions of KRS chapters 136, 139, 141, 337, 338, 341, and 342. These statutes relate to corporate and utility tax, sales and use tax, income tax, wages and hours laws, occupational safety and health laws, unemployment insurance laws, and workers compensation insurance laws, respectively

To comply with the provisions of KRS 45A.485, the Contractor and all subcontractors performing work under the contract shall report any such final determination(s) of violation(s) to the Commonwealth by providing the following information regarding the final determination(s): the KRS violated, the date of the final determination, and the state agency which issued the final determination.

KRS 45A.485 also provides that, for the duration of any contract, the Contractor and all subcontractors performing

FISCAL COURT ORDERS

JULY 19, 2022

BOOK 43

REGULAR SESSION OF NELSON FISCAL COURT

PAGE 679

NELSON COUNTY
BRIDGE PROJECT
ON HILTON ROAD (CR 1008)
\$80,000 – CB01 BRIDGE FUNDS

work under the contract shall be in continuous compliance with the provisions of those statutes, which apply to their operations, and that their failure to reveal a final determination, as described above, or failure to comply with the above statutes for the duration of the contract, shall be grounds for the Commonwealth's cancellation of the contract and their disqualification from eligibility for future state contracts for a period of two (2) years.

Contractor must check one:

_____ The Contractor has not violated any of the provisions of the above statutes within the previous five (5) year period.

_____ The Contractor has violated the provisions of one or more of the above statutes within the previous five (5) year period and has revealed such final determination(s) of violation(s). Attached is a list of such determination(s), which includes the KRS violated, the date of the final determination, and the state agency which issued the final determination.

18.00 Discrimination:

This section applies only to contracts disbursing federal funds, in whole or part, when the terms for receiving those funds mandate its inclusion. Discrimination (because of race, religion, color, national origin, sex, sexual orientation, gender identity, age, or disability) is prohibited. During the performance of this contract, the Contractor agrees as follows:

The Contractor will not discriminate against any employee or applicant for employment because of race, religion, color, national origin, sex, sexual orientation, gender identity or age. The Contractor further agrees to comply with the provisions of the Americans with Disabilities Act (ADA), Public Law 101-336, and applicable federal regulations relating thereto prohibiting discrimination against otherwise qualified disabled individuals under any program or activity. The Contractor agrees to provide, upon request, needed reasonable accommodations. The Contractor will take affirmative action to ensure that applicants are employed and that employees are treated during employment without regard to their race, religion, color, national origin, sex, sexual orientation, gender identity, age or disability. Such action shall include, but not be limited to the following: employment, upgrading, demotion or transfer; recruitment or recruitment advertising; layoff or termination; rates of pay or other forms of compensations; and selection for training, including apprenticeship. The Contractor agrees to post in conspicuous places, available to employees and applicants for employment, notices setting forth the provisions of this non-discrimination clause.

In all solicitations or advertisements for employees placed by or on behalf of the Contractor, the Contractor

FISCAL COURT ORDERS

JULY 19, 2022

BOOK 43

REGULAR SESSION OF NELSON FISCAL COURT

PAGE 680

NELSON COUNTY
BRIDGE PROJECT
ON HILTON ROAD (CR 1008)
\$80,000 – CB01 BRIDGE FUNDS

will state that all qualified applicants will receive consideration for employment without regard to race, religion, color, national origin, sex, sexual orientation, gender identity, age or disability.

The Contractor will send to each labor union or representative of workers with which he/she has a collective bargaining agreement or other contract or understanding a notice advising the said labor union or workers' representative of the Contractor's commitments under this section and shall post copies of the notice in conspicuous places available to employees and applicants for employment. The Contractor will take such action with respect to any subcontract or purchase order as the administering agency may direct as a means of enforcing such provisions, including sanctions for noncompliance.

The Contractor will comply with all provisions of Executive Order No. 11246 of September 24, 1965, as amended, and of the rules, regulations and relevant orders of the Secretary of Labor.

The Contractor will furnish all information and reports required by Executive Order No. 11246 of September 24, 1965, as amended, and by the rules, regulations and orders of the Secretary of Labor, or pursuant thereto, and will permit access to his/her books, records and accounts by the administering agency and the Secretary of Labor for purposes of investigation to ascertain compliance with such rules, regulations and orders.

In the event of the Contractor's noncompliance with the nondiscrimination clauses of this contract or with any of the said rules, regulations or orders, this contract may be cancelled, terminated or suspended in whole or in part, and the Contractor may be declared ineligible for further government contracts or federally-assisted construction contracts in accordance with procedures authorized in Executive Order No. 11246 of September 24, 1965, as amended, and such other sanctions that may be imposed and remedies invoked as provided in or as otherwise provided by law.

The Contractor will include the provisions of paragraphs (1) through (7) of section 202 of Executive Order 11246 in every subcontract or purchase order unless exempted by rules, regulations or orders of the Secretary of Labor, issued pursuant to section 204 of Executive Order No. 11246 of September 24, 1965, as amended, so that such provisions will be binding upon each subcontractor or vendor. The Contractor will take such action with respect to any subcontract or purchase order as the administering agency may direct as a means of enforcing such provisions including sanctions for noncompliance; provided, however, that in the event a Contractor becomes involved in, or is threatened with, litigation with a subcontractor or vendor as a result of such direction by the agency, the Contractor may request the United States to enter into such litigation to protect the interests of the United States.

FISCAL COURT ORDERS

JULY 19, 2022

BOOK 43

REGULAR SESSION OF NELSON FISCAL COURT

PAGE 681

NELSON COUNTY
BRIDGE PROJECT
ON HILTON ROAD (CR 1008)
\$80,000 - CB01 BRIDGE FUNDS

IN WITNESS WHEREOF, the parties have caused this agreement to be executed by its officers, thereunto duly authorized.

NELSON COUNTY FISCAL COURT

By: _____
COUNTY JUDGE/EXECUTIVE

Date: _____

TRANSPORTATION CABINET USE:

APPROVED AS TO FORM AND LEGALITY:

By: _____
OFFICE OF LEGAL SERVICES

Date: _____

TRANSPORTATION CABINET
DEPARTMENT OF RURAL AND MUNICIPAL AID

By: _____
DEPARTMENT COMMISSIONER

Date: _____

COMMONWEALTH OF KENTUCKY
TRANSPORTATION CABINET

By: _____
CABINET SECRETARY

Date: _____

FISCAL COURT ORDERS

JULY 19, 2022

BOOK 43

REGULAR SESSION OF NELSON FISCAL COURT

PAGE 682

Load Rating for County Routes

A Load rating shall be required for all culverts, 20 feet and above, before they are opened to traffic. They shall be done using LRFR, Load and Resistance Factor Rating method. They shall be done in accordance with the AASHTO MBE (The Manual for Bridge Evaluation, current edition); the AASHTO LRFD Bridge Design Specifications, current edition; the FHWA Load Rating for the FAST Act's Emergency Vehicles; and the Kentucky Bridge Inspection Procedures Manual, current edition.

Ratings shall be provided for design loads using HL93 for Inventory and Operating; legal loads for KYTC's Types 1-4 Posting trucks and Single- Unit Specialized Hauling Vehicles 4-7, and Emergency Vehicles EV2 and EV3.

The axle spacing and weight of the rating vehicles are shown in the following figures. See AASHTO LRFD Bridge Design Specifications for details on HL93.

Truck Type 1

40,000 lbs
20.00 tons



Truck Type 2

56,700 lbs
28.35 tons



Truck Type 3

73,500 lbs
36.75 tons



Truck Type 4

80,000 lbs
40.00 tons



Figure 1: KYTC Standard Analysis Trucks

FISCAL COURT ORDERS

JULY 19, 2022

BOOK 43

REGULAR SESSION OF NELSON FISCAL COURT

PAGE 683

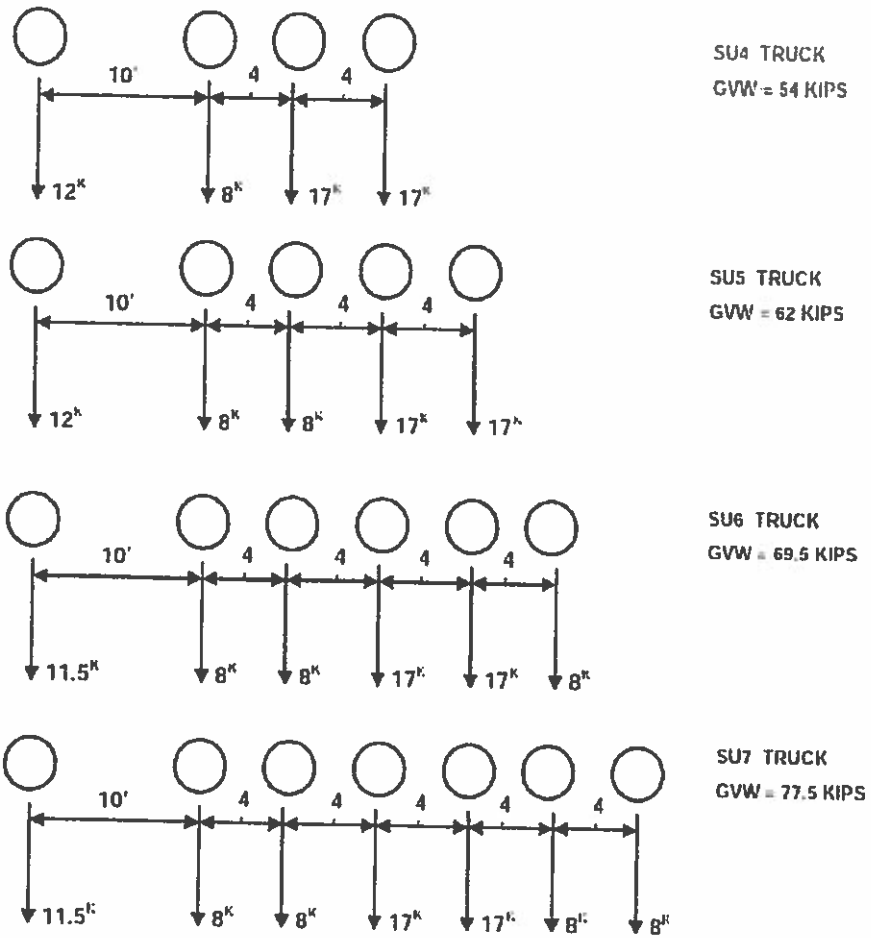

Figure 2: Single-Unit Special Hauling Vehicles, SU4-SU7

FISCAL COURT ORDERS

JULY 19, 2022

BOOK 43

REGULAR SESSION OF NELSON FISCAL COURT

PAGE 684

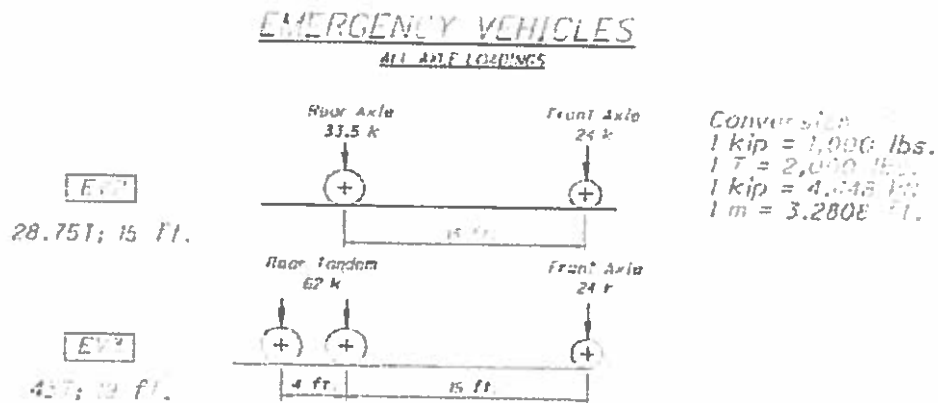

Figure 3: Emergency Vehicles

The controlling load ratings for each rating type and vehicle shall be presented in a table, such as this one, with the controlling section and location.

Rating Type	Rating Vehicle	Controlling Rating	Tons	Controlling Section	Controlling Location
		Factor			
Inventory	HL93	0.8		Arch	Buckling at top
Operating	HL93	1.02		Arch	Buckling at top
Posting	KY Type 1	2.39	47.8	Arch	Buckling at pier/bearing
Posting	KY Type 2	1.69	47.9	Arch	Buckling at pier/bearing
Posting	KY Type 3	1.33	48.9	Arch	Flexure at top
Posting	KY Type 4	1.34	53.6	Arch	Shear at top
Posting	SU4	1.8	48.6	Arch	Shear at pier/bearing
Posting	SU5	1.6	49.6	Arch	Buckling at top
Posting	SU6	1.43	49.7	Arch	Buckling at top
Posting	SU7	1.31	50.8	Arch	Buckling at top
Posting	EV2	1.05	30.5	Arch	Flexure at top
Posting	EV3	1.02	43.9	Arch	Flexure at top

Table 2: Example Table of Controlling Load Ratings

The summary shall include the table of controlling load ratings, the date the load rating was completed, design loading of the culvert, the road that crosses the culvert, and the facility that the road crosses (i.e. KY 99 over Yellow Creek).

FISCAL COURT ORDERS

JULY 19, 2022

BOOK 43

REGULAR SESSION OF NELSON FISCAL COURT

PAGE 685

Nelson Co FY23 80/20 Project # 15425 - \$80,000

AUTHORIZATION LOCATION						
ITEM NUMBER	COUNTY	DIST	FACILITY NAME	ROUTE	LENGTH	SCOPE
1	Nelson	4	HILTON ROAD	CR 1008	1.029 - 1.043 (0.014 MI)	BRIDGE - FROM CR 1058, BOUTH 0.017 MILES, EXTENDING TO ENDING MP 1.043.

FISCAL COURT ORDERS

JULY 19, 2022

BOOK 43

REGULAR SESSION OF NELSON FISCAL COURT

PAGE 686

Nelson County Road Department

Report to Fiscal Court

July 19, 2022

- c **Culvert Installation/Replacements**
 - Installed drainage pipe at Pembroke Dr
 - Replaced more culverts on Hall Simpson Rd. Will replace two more this week.
 - Installed a culvert on Sullivan Ln
 - Replaced a culvert on Sunshine Dr off of Mary Jo Blvd.
- c **Storms**
 - Removed several fallen trees during this last couple of storms
- c **Bridge Approaches**
- c **Paved approaches to the new Woodlawn Bridge and Dee Head Bridge**
- c **Road Repair**
 - Repaired the road at the end of Fogle Ln.
- c **Started trimming weeds and brush back on Icetown Rd yesterday. We had a couple of large trees fall during the Sunday night storms so our crew got called off to address those. We will return back to Icetown as time permits.**
- c **We are patching asphalt on Wetherby Dr. today.**
- c **Mowing crew is in District 3 on its 3rd round. We will start District 4 shortly.**

FISCAL COURT ORDERS

JULY 19, 2022

BOOK 43

REGULAR SESSION OF NELSON FISCAL COURT

PAGE 687

Population Reporting Form 7/19/2022

Main Jail			
<u>Secure Male</u>		<u>Secure Female</u>	
Class D	6	Class D	0
Alt. Sentence	0	Alt. Sentence	0
Controlled Intake	12	Controlled Intake	5
Parole Violators	2	Parole Violators	1
Federal Inmates	0	Federal Inmates	0
County Inmates	52	County Inmates	14
Total	72	Total	20
<u>Non Secure Male</u>		<u>Non Secure Female</u>	
Class D	7	Class D	0
Class C	2	Class C	1
Alt. Sentence	4	Alt. Sentence	2
Total	13	Total	3

Restricted Custody Center (RCC)			
<u>Non Secure Male</u>		<u>Non Secure Female</u>	
Class D	_____	Class D	_____
Class C	_____	Class C	_____
Alt. Sentence	_____	Alt. Sentence	_____
Federal Inmates	_____	Federal Inmates	_____
County Inmates	_____	County Inmates	_____
Total	0	Total	0

Jail Restricted Custody (JRC)			
<u>Non Secure Male</u>		<u>Non Secure Female</u>	
Class D	_____	Class D	_____
Class C	_____	Class C	_____
Alt. Sentence	_____	Alt. Sentence	_____
Federal Inmates	_____	Federal Inmates	_____
County Inmates	_____	County Inmates	_____
Total	0	Total	0

Secure is CI, PV, Level 2A, 3, 4, 5 Non Secure is Level 1 or 2

Revised 07/27/2018(2)

FISCAL COURT ORDERS

JULY 19, 2022

BOOK 43

REGULAR SESSION OF NELSON FISCAL COURT

PAGE 688

Population Analysis By Classification And Sex 07/20/2022 to 07/20/2022

Classification Summary

Date	AS	CC-1	CD-1	CD-3	CI	CIRCUIT COURT	COUNTY-DISTRICT	COURT ONLY	DE	DRUG COURT	FOR ANOTH ER COURT	PAROLE VIOLATI ON	Grand Total
7/20/2022	6	3	7	5	17	46	13	4	1	1	2	3	108
Totals													

Classification Specific Breakdown

Classification	Date	Totals	Female	Male	Total
AS	7/20/2022	2		2	2
CC-1	7/20/2022	1		1	1
CD-1	7/20/2022	7		7	7
CD-3	7/20/2022	5		5	5
CI	7/20/2022	12		12	12
CIRCUIT COURT	7/20/2022	41		41	41
COUNTY-DISTRICT	7/20/2022	7		7	7
COURT ONLY	7/20/2022	4		4	4
DE	7/20/2022	1		1	1
DRUG COURT	7/20/2022	2		2	2
FOR ANOTH ER COURT	7/20/2022	1		1	1
PAROLE VIOLATION	7/20/2022	2		2	2
Grand Total		23		85	108

Population Analysis By Classification And Sex Report
JailTracker @ Report Printed On 07/19/2022 08:40 by UserID 117

FISCAL COURT ORDERS

JULY 19, 2022

BOOK 43

REGULAR SESSION OF NELSON FISCAL COURT

PAGE 689

7/19/2022

Monthly EMS Run Totals
As of June, 2022

Areas	Monthly Completed Runs	Monthly Non Transport	Monthly Total Calls	Year-To-Date Calls	Monthly Charges	Year-To-Date Charges	Average Charge per Run
Bardstow Area	402	110	512	6254	\$ 481,301.50	\$ 5,503,229.90	\$ 879.95
Bloomfield Area	32	15	47	439	\$ 41,517.40	\$ 404,150.34	\$ 920.82
New Haven Area	34	10	44	425	\$ 47,465.10	\$ 382,838.85	\$ 900.80
Boston Area	6	3	9	222	\$ 8,419.30	\$ 140,403.30	\$ 632.45
Cox's Creek Area	17	11	28	408	\$ 17,416.45	\$ 268,843.50	\$ 658.93
TOTAL	491	211	702	7810	\$ 596,119.75	\$ 6,699,465.89	\$ 857.81
Average Per Day Collections (YTD)	18.5	7.0	23.4	21.4	\$ 19,870.66	\$ 18,383.18	\$ 2,516,188.00
Collection Per Run						\$ 334.07	\$ 507.51
Cost Per Run							\$ 173.44
Difference							
RETURNS TO STATION I		62					
Previous Year 2021	Totals	661	7771	\$ 643,843.76	\$ 6,129,059.88		
Difference From Current Year	Totals	41	39	\$ 82,270.99	\$ 870,408.21		
Previous Year 2020	Totals	694	6932	\$ 486,006.21	\$ 6,774,993.60		
Difference From Current Year	Totals	108	638	\$ 141,113.84	\$ 927,492.29		
Previous Year 2019	Totals	633	6881	\$ 508,466.80	\$ 6,116,780.24		
Difference From Current Year	Totals	69	989	\$ 87,650.95	\$ 1,583,748.65		
Previous Year 2018	Totals	681	6978	\$ 407,841.62	\$ 4,771,268.82		
Difference From Current Year	Totals	121	632	\$ 189,278.13	\$ 1,925,208.97		
Previous Year 2017	Totals	617	6868	\$ 424,926.64	\$ 4,688,899.17		
Difference From Current Year	Totals	85	662	\$ 171,184.11	\$ 2,000,666.72		

19 LEFT ASSIST

June, 2022